

SERRURERIE DÉCORATIVE • DOOR FURNITURES • DEKORATIVE TÜRBESCHLÄGE



Varia by Karl Leuthenmayr
Fürstenriederstrasse 39
80686 München

Tel: +49 (0)89 220 454
Tel: +49 (0)89 291 36 87

Varia@varia-int.com
www.varia-int.com



Heurtoirs

Doorknockers - Türklopfer



H1300
H245x90mm

7

- Livrés avec tige filetée et cache-écrou
—+—+—+—+—
- Fixing supplied
—+—+—+—+—
- Mit einem Schraubspindel und Abdeckung für Schraubenmutter geliefert.

Heurtoirs

Doorknockers - Türklopfer

H1300 * 1 3 5 6 7 • H245x90mm

* 1 Noir/Black/Schwarz • 3 Poli verni/Pewter/Poliert lackiert • 5 Laiton massif/Brass/Vollmessing •
6 Rouillé ciré/Rust effect/Gerostet geböhnt • 7 Laiton vieilli/Antique brass/Geältert Messing



H15
H190mm

7



H19
H240mm

3



H17
H165mm

5

- Livrés avec tige filetée et cache-écrou
- Fixing supplied
- Mit einem Schraubspindel und Abdeckung für Schraubenmutter geliefert.

Heurtoirs

Doorknockers - Türklopfer

H15Renaissance * 1 3 5 6 7 • H190mm H17Louis XIV * 1 3 5 6 7 • H165mm H19Renaissance * 1 3 5 6 7 • H240mm

* 1 Noir/Black/Schwarz • 3 Poli verni/Pewter/Poliert lackiert • 5 Laiton massif/Brass/Vollmessing • 6 Rouillé ciré/Rust effect/Gerostet gebohntert • 7 Laiton vieilli/Antique brass/Geältert Messing



H5
H263mm

7

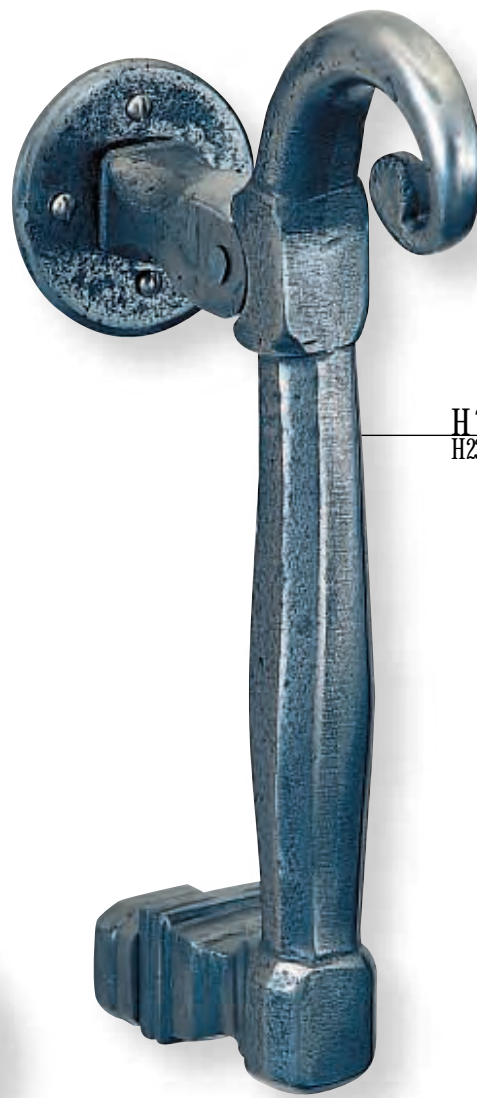

H7
H230mm

3



H11
H130mm

5

- Livrés avec tige filetée et cache-écrou
- Fixing supplied
- Mit einem Schraubspindel und Abdeckung für Schraubenmutter geliefert.

Heurtoirs

Doorknockers - Türklopfer

H5 Poisson XVII* 1 3 5 6 7 • H.263mm H7 Crosse d'Evêque* 1 3 5 6 7 • H.230mm H11 Campagnard XV* 1 3 5 6 7 • H130mm

* 1 Noir/Black/Schwarz • 3 Poli verni/Pewter/Poliert lackiert • 5 Laiton massif/Brass/Vollmessing • 6 Rouillé ciré/Rust effect/Gerostet gebohntert • 7 Laiton vieilli/Antique brass/Geältert Messing



- Livrés avec tige filetée et cache-écrou

- Fixing supplied

- Mit einem Schraubspindel und Abdeckung für Schraubenmutter geliefert.

Heurtoirs

Doorknockers - Türklopfer

H1303 * 1 3 5 6 7 • H200mm H1302 Style Campagnard * 1 3 5 6 7 • H130mm H3 Grand Sicle * 1 3 5 6 7 • H170mm

* 1 Noir/Black/Schwarz • 3 Poli verni/Pewter/Poliert lackiert • 5 Laiton massif/Brass/Vollmessing • 6 Rouillé ciré/Rust effect/Gerostet gebohntert • 7 Laiton vieilli/Antique brass/Geältert Messing



7 H1301
H275mm



3 H9
H145mm



H1304
H240mm **5**

- Livrés avec tige filetée et cache-écrou
- Fixing supplied
- Mit einem Schraubspindel und Abdeckung für Schraubenmutter geliefert.

Heurtoirs

Doorknockers - Türklopfer

H1301 * **1 3 5 6 7** • H.275mm H9 Anreau d'Albi XV^e siècle * **1 3 5 6 7** • H.145mm H1304 * **1 3 5 6 7** • H.240mm

* **1** Noir/Black/Schwarz • **3** Poli verni/Pewter/Poliert lackiert • **5** Laiton massif/Brass/Vollmessing • **6** Rouillé ciré/Rust effect/Gerostet gebohntert • **7** Laiton vieilli/Antique brass/Geältert Messing



H1305
H225 mm

3

- Livrés avec tige filetée et cache-écrou
- Fixing supplied
- Mit einem Schraubspindel und Abdeckung für Schraubenmutter geliefert.

Heurtoirs

Doorknockers - Türklopfer

H1305 * 1 3 5 6 7 • H225 mm

* 1 Noir/Black/Schwarz • 3 Poli verni/Pewter/Poliert lackiert • 5 Laiton massif/Brass/Vollmessing • 6 Rouillé ciré/Rust effect/Gerostet geböhnt • 7 Laiton vieilli/Antique brass/Geältert Messing



Accessoires Portes d'entrée

Door furnitures - Zubehör für Einganstüren

Serrures avec mécanisme/Operating locks/Verriegelungen

Grille de Judas/Judas grille/Spiongitter

Porte de Judas/Judas door/Tür für Spion

Entrée boîte aux lettres/Letter plates/Briefeinwurfe

Entrebâilleur/Door holder/Sicherheitsverschluß

Bouton de sonnette/Bell push/Klingeltaster

Chiffres/Numerals/Ziffer

Lettre/Letter/Buchstabe

Boutons/Knobs/Turknöpfe

Platine à bouton/Knobs backplate/Klingelplatte

Plaque d'identité/Nameplate/Namenschild

Clous/Nails/Nägel



5 1701
H150x165 mm



1702
H150x115 mm **5**



BT1010
H65x55 mm **5**



A 1801
H52x42 mm **5**

- Livrée avec kit de fixation
- Supplied with screws.
- Mit einem Befestigungs-
kit geliefert.

Accessoires porte

Door furnitures - Zubehör für Einganstüren

1701 Coffre de serrure avec mécanisme * **5 7**
(2 clés) avec gâche • H150x165mm

1701 bis Gâche à répétition sans mécanisme* **5 7**

1702 Gâche seule * **5 7** • H150x115 mm

BT 1010 Bouton * **5 7** • H.65x55 mm

A 1801 Clé * **5 7** • H.52x42 mm

* **5** Laiton massif/Brass/Vollmessing • **7** Laiton vieilli/Antique brass/Geältert Messing



Grille de Judas
H180x180mm

7

Porte de Judas
H160x160mm

7



- Grille de Judas
livrée avec vis 3 x 16 et
2 tiges filetées M6.
- Porte de Judas
livrée avec 4 clous
décoratifs.



- Judas grille : supplied with
M6 x 16 and 2 M6 screws.
- Judas door : supplied with
4 nails.



- Spiongitter : mit 3 x 16
Schrauben und
2 Schraubspindel M6 geliefert.
- Tür für Spion : mit 4 Nägeln
geliefert.

Judas

Judas - Spiongitter

Grille de Judas * 1 3 5 6 7 • 180x180mm Porte de Judas * 1 3 5 6 7 • 160x160mm

* 1 Noir/Black/Schwarz • 3 Poli verni/Pewter/Poliert lackiert • 5 Laiton massif/Brass/Vollmessing •
6 Rouillé ciré/Rust effect/Gerostet gebohntert • 7 Laiton vieilli/Antique brass/Geältert Messing



Entrée boîte aux lettres
H55 x 345 mm

3



Bouton de sonnette
H65 x 37 mm

5



Entrebâilleur
H130 x 105 mm

7



Chiffre
H100 mm

5



Lettre
H50 mm

5



Chiffre
H75 mm

5

• Livrés avec kit de fixation



• Fixing supplied



• Mit einem Befestigungs-
kit geliefert

Accessoires porte

Door furnitures - Zubehör für Einganstüren

Entrée boîte aux lettres * 1 3 5 6 7
• 55 x 345 mm

Bouton de sonnette avec mécanisme* 1 3 5 6 7
• 65 x 37 mm

Entrebâilleur * 1 3 5 6 7
• 130 x 105 mm

Chiffre * 5 7
• H 100 mm

Chiffre * 5 7
• H 75 mm

Lettre * 5 7
• H 50 mm

* 1 Noir/Black/Schwarz • 3 Poli verni/Pewter/Poliert lackiert • 5 Laiton massif/Brass/Vollmessing •
6 Rouillé ciré/Rust effect/Gerostet gebohntert • 7 Laiton vieilli/Antique brass/Geältert Messing



Chapeau de gendarme
H122 x 166 mm

5



Plaque d'identité
H33 x 125 mm

5

- Plaques
« Chapeau de gendarme »
ou « Ovale »
H 124 x 163 mm (à préciser).
- Livrées avec visserie.
- Finitions :
laiton uniquement.
- « French style » nameplate.
Available in « Oval » design
H 124 x 163 mm
(please specify).
- Supplied with screw.
- Finish: only brass.
- « Französische Styl »
Namenschild auch in « Oval »
Design H 124 x 163 mm
(zum Notieren).
- Mit Schrauben geliefert.
- Fertigarbeiten :
nur Vollmessing

Plaques d'identité

Nameplate - Namenschild

Chapeau de gendarme * 5 • H122 x 166 mm

Plaque d'identité * 5 • H33 x 125 mm



BT 275
H105 x 90mm

5



BT 278 lisse
H76 x 75mm

3



BT 278 martelé
H76 x 75mm

7



BT 400
H110 x 120mm

3



BT 1000
H98 x 58mm

7

- Livrés avec tige filetée ou carré de 7 mm (à préciser).
- Les références BT 275, BT 400 et BT 1000 en tige filetée ou à chaînette (à préciser).



- Supplied with threaded spindle 7 mm or 8 mm spindle (please specify).
- The product numbers BT 275 - BT 400 and BT 1000 : with threaded spindle only.



- Mit Schraubspindel oder Viereck von 7 mm geliefert : zum Notieren.
- Die Referenz BT 275 - BT 400 und BT 1000 mit Schraubspindel oder Vierkant : zum Notieren.

Accessoires porte

Door furnitures - Zubehör für Einganstüren

BT 275 * 1 3 5 6 7 • H105x90mm BT 278 lisse * 1 3 5 6 7 • H76x75mm BT 278 martelé * 1 3 5 6 7 • H76x75mm
BT 400 * 1 3 5 6 7 • H110x120mm BT 1000 * 5 7 • H98x58mm

* 1 Noir/Black/Schwarz • 3 Poli verni/Pewter/Poliert lackiert • 5 Laiton massif/Brass/Vollmessing •
6 Rouillé ciré/Rust effect/Gerostet gebohnt • 7 Laiton vieilli/Antique brass/Geältert Messing

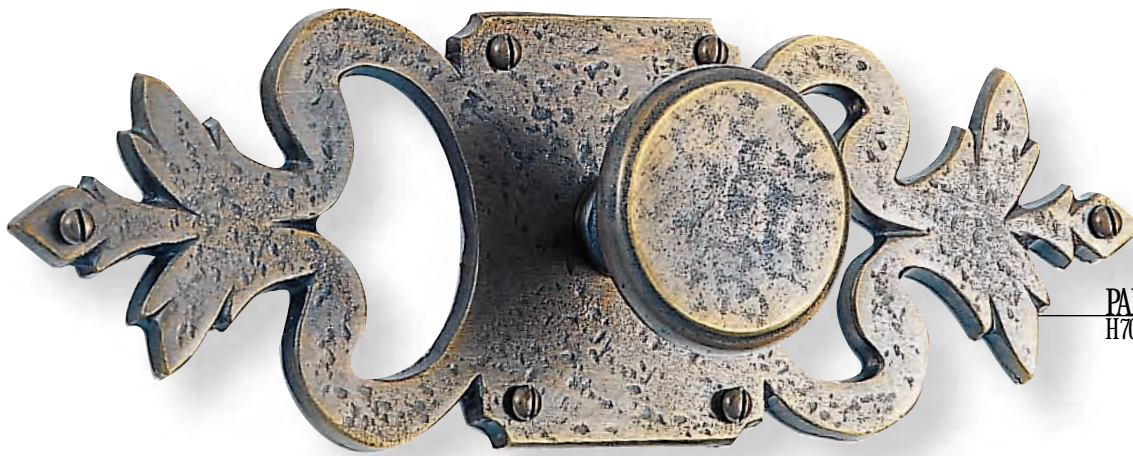

PAB 267
H70x218mm

7



PAB 267 bis
H40x140mm

1

- Livrés avec vis 3 x 16.



- Supplied with
MB x 16 screws



- Mit einer
3 x 16 Schraube geliefert.



PAB 269
H70x195mm

3

Accessoires porte

Door furnitures - Zubehör für Einganstüren

PAB 267 * 1 3 5 6 7 • H70x218mm PAB 267bis * 1 3 5 6 7 • H40x140mm PAB 269 * 1 3 5 6 7 • H70x195mm

* 1 Noir/Black/Schwarz • 3 Poli verni/Pewter/Poliert lackiert • 5 Laiton massif/Brass/Vollmessing •
6 Rouillé ciré/Rust effect/Gerostet gebohntert • 7 Laiton vieilli/Antique brass/Geältert Messing



C 401
H36x36mm **3**



C 402
H33x33mm **3**



C 404
H19x19mm **3**

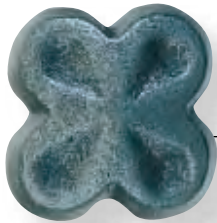

C 403
H27x27mm **3**



C 405
H30x30mm **3**



C 406
Ø 55mm **5**



C 407 bis
H25x25mm **7**



C 407 ter
H13x13mm **5**

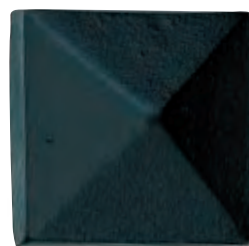

C 407
H33x33mm **1**

- Fixation avec vis à bois 5 x 30 mm
--->>>---
- Fixing with M5 x 30 screws.
--->>>---
- Befestigung mit Holzschrauben 5 x 30 mm

Clous

Nails - Nägel

C401 Carcassonne * **1 3 6** • 36x36mm

C402 Bouton de fleur * **1 3 6** • 33x33mm

C404 Florentin * **1 3 6** • 19x19mm

C403 Graine * **1 3 6** • 27x27mm

C405 Tolède * **1 3 6** • 30x30mm

C406 Soleil * **1 3 5 6 7** • Ø55mm

C407 bis Pointe Diamant * **1 3 5 6 7** • 25x25mm

C407 ter Pointe Diamant * **1 3 5 6 7** • 13x13mm

C407 Pointe Diamant * **1 3 5 6 7** • 33x33mm

* **1** Noir/Black/Schwarz • **3** Poli verni/Pewter/Poliert lackiert • **5** Laiton massif/Brass/Vollmessing • **6** Rouillé ciré/Rust effect/Gerostet gebohnt • **7** Laiton vieilli/Antique brass/Geältert Messing

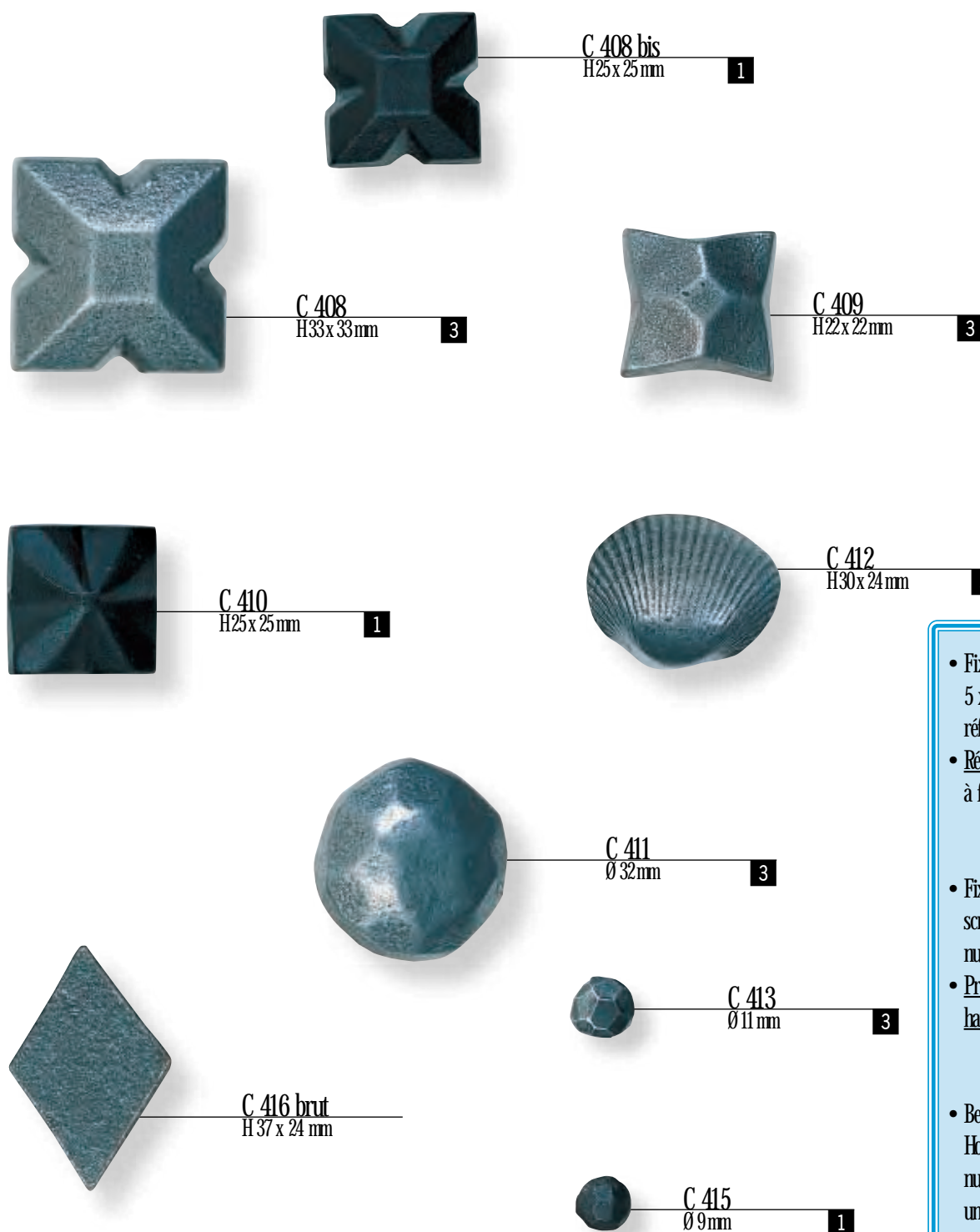

- Fixation avec vis à bois 5 x 30 mm excepté les références C 413 et C 415.
- Référence C 416 « Losange » : à frapper.

- Fixing with M5 x 30 screws (except product numbers C 413 and C 415).
- Product number C 416 : hammered to be stamped.

- Befestigung mit Holzschrauben 5 x 30 mm nur nicht die Referenz C 413 und C 415.
- Die Referenz C 416 « Raute » : zum Schlagen

Clous

Nails - Nägel

C408 Facettes	* 1 3 6 • 33x33mm	C408bis Facettes	* 1 3 6 • 25x25mm	C409 Vieux Rouen	* 1 3 6 • 22x22mm
C410 Croix de Malte	* 1 3 6 • 25x25mm	C412 Coquillage	* 1 3 6 • 30x24mm	C411 Cabochon martelé	* 1 3 5 6 7 • Ø32mm
C416 Losange brut	• H37x24mm	C413 Cabochon martelé	* 1 3 6 • Ø11mm	C415 Cabochon martelé	* 1 3 6 • Ø9mm

* 1 Noir/Black/Schwarz • 3 Poli verni/Pewter/Pollert lackiert • 5 Laiton massif/Brass/Vollmessing • 6 Rouillé ciré/Rust effect/Gerostet geböhnt • 7 Laiton vieilli/Antique brass/Geältert Messing



Béquilles

Lever handles - Türklinken

Béquilles/Lever handles/Türklinken



BE 289 martelée
L 85 mm

7



BE 277 ter lisse
L 105 mm

7

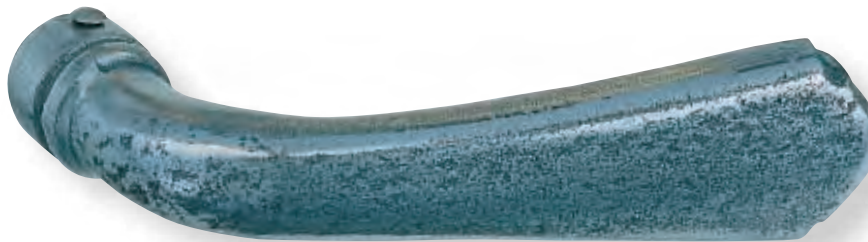

BE 277 ter martelée
L 105 mm

3



BE 277 martelée
L 115 mm

5

- Livrées avec carré de 7 mm, goupille et joint téflon
- Autres percements : carré de 6 ou 8 mm (à préciser).
- Finitions : lisse ou martelée (à préciser).
- Autres finitions : nous consulter.



- Supplied with 6, 7 or 8 mm spindle. Fixed with pin and washer.
- Grubscrew and circlip fixing available on request.
- Other finish : please contact us.



- Mit einem 7 mm Viereck, Stifte und Verbindung aus Teflon geliefert.
- Andere Bohrungen : « 6, 8 Viereck » (zum Notieren).
- Fertigarbeiten : schlicht oder gehämmert (zum Notieren).
- Andere Fertigarbeiten : bitte fragen Sie uns.

Béquilles

Lever handles - Türklinken

BE 277 lisse ou martelée * 1 3 5 6 7 • L 115 mm BE 277 ter lisse ou martelée * 1 3 5 6 7 • L 105 mm BE 289 lisse ou martelée * 1 3 5 6 7 • L 85 mm

* 1 Noir/Black/Schwarz • 3 Poli verni/Pewter/Poliert lackiert • 5 Laiton massif/Brass/Vollmessing • 6 Rouillé ciré/Rust effect/Gerostet gebohnt • 7 Laiton vieilli/Antique brass/Geältert Messing



BE 255 bis
L.100mm

5



BE 281
L.125mm

7



BE 263
L.100mm

3

- Livrées avec carré de 7 mm, goupille et joint téflon.
- Autres percements : carré de 6 ou 8 mm (à préciser).
- Autres finitions : nous consulter.
- Main droite ou gauche (à préciser).



- Supplied with 6, 7 or 8 mm spindle. Fixed with pin and washer.
- Grubscrew and circlip fixing available on request.
- Other finish: please contact us.
- Handed left or right: please specify.



- Mit einem 7 mm Viereck, Stifte und Verbindung aus Teflon geliefert.
- Andere Bohrungen: « 6, 8 Viereck » (zum Notieren).
- Andere Fertigarbeiten: bitte fragen Sie uns.
- Rechthand oder Linkshand (zum Notieren).

Béquilles

Lever handles - Türklinken

BE 255 bis * 1 3 5 6 7 • L.100mm BE 281 * 1 3 5 6 7 • L.125mm BE 263 * 1 3 5 6 7 • L.100mm

* 1 Noir/Black/Schwarz • 3 Poli verni/Pewter/Poliert lackiert • 5 Laiton massif/Brass/Vollmessing • 6 Rouillé ciré/Rust effect/Gerostet gebohnt • 7 Laiton vieilli/Antique brass/Geältert Messing

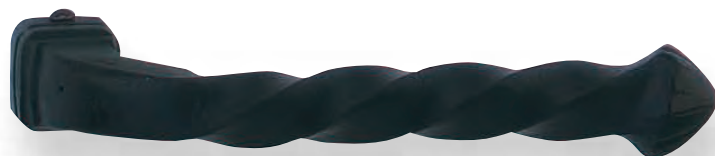

BE 259
L.110mm

1



BE 1214
L.125mm

3



BE 267 bis
L.130mm

7



BE 267
L.110mm

5



BE 251
L.110mm

3

- Livrées avec carré de 7 mm, goupille et joint téflon.
- Autres percements : carré de 6 ou 8 mm (à préciser).
- Autres finitions : nous consulter.



- Supplied with 6, 7 or 8 mm spindle. Fixed with pin and washer.
- Grubscrew and circlip fixing available on request.
- Other finish : please contact us.



- Mit einem 7 mm Viereck, Stifte und Verbindung aus Teflon geliefert.
- Andere Bohrungen : « 6, 8 Viereck » (zum Notieren).
- Andere Fertigarbeiten : bitte fragen Sie uns.

Béquilles

Lever handles - Türklinken

BE 251 * 1 3 5 6 7 • L.110mm BE 267 * 1 3 5 6 7 • L.110mm BE 267 bis * 1 3 5 6 7 • L.130mm
 BE 1214 * 1 3 6 • L.125mm BE 259 * 1 3 6 • L.110mm

* 1 Noir/Black/Schwarz • 3 Poli verni/Pewter/Poliert lackiert • 5 Laiton massif/Brass/Vollmessing •
 6 Rouillé ciré/Rust effect/Gerostet gebohnt • 7 Laiton vieilli/Antique brass/Geältert Messing



BE 279
L 120 mm **3**



BE 275
L 125 mm **5**



BE 269
L 120 mm **7**

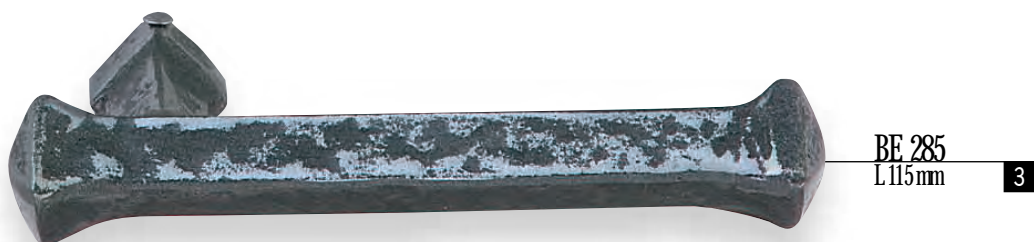

BE 285
L 115 mm **3**

- Livrées avec carré de 7 mm, goupille et joint téflon.
- Autres percements : carré de 6 ou 8 mm (à préciser).
- Autres finitions : nous consulter.
- Référence BE 279 : Main droite ou gauche (à préciser).



- Supplied with 6, 7 or 8 mm spindle. Fixed with pin and washer.
- Grubscrew and circlip fixing available on request.
- Other finish : please contact us.
- Number BE 279 : Handed left or right: please specify.



- Mit einem 7 mm Viereck, Stifte und Verbindung aus Teflon geliefert.
- Andere Bohrungen : « 6, 8 Viereck » (zum Notieren).
- Andere Fertigarbeiten : bitte fragen Sie uns.
- Referenz BE 279 : Rechthand oder Linkshand (zum Notieren).

Béquilles

Lever handles - Türklinken

BE 279 * **1 3 5 6 7** • L 120 mm BE 275 * **1 3 5 6 7** • L 125 mm BE 269 * **1 3 5 6 7** • L 120 mm
BE 285 * **1 3 5 6 7** • L 115 mm

* **1** Noir/Black/Schwarz • **3** Poli verni/Pewter/Poliert lackiert • **5** Laiton massif/Brass/Vollmessing •
6 Rouillé ciré/Rust effect/Gerostet gebohnt • **7** Laiton vieilli/Antique brass/Geältert Messing



BE 291 bis
L112mm

7



BE 293
L110mm

5



BE 291
L135mm

3

- Livrées avec carré de 7 mm, goupille et joint téflon.
- Autres percements : carré de 6 ou 8 mm (à préciser).
- Autres finitions : nous consulter.



- Supplied with 6, 7 or 8 mm spindle. Fixed with pin and washer.
- Grubscrew and circlip fixing available on request.
- Other finish : please contact us.



- Mit einem 7 mm Viereck, Stifte und Verbindung aus Teflon geliefert.
- Andere Bohrungen : « 6, 8 Viereck » (zum Notieren).
- Andere Fertigarbeiten : bitte fragen Sie uns.

Béquilles

Lever handles - Türklinken

BE 291 bis * 1 3 5 6 7 • L112mm BE 293 * 5 7 • L110mm BE 291 * 1 3 5 6 7 • L135mm

* 1 Noir/Black/Schwarz • 3 Poli verni/Pewter/Poliert lackiert • 5 Laiton massif/Brass/Vollmessing • 6 Rouillé ciré/Rust effect/Gerostet gebohnt • 7 Laiton vieilli/Antique brass/Geältert Messing



BE 1210
L.140mm **3**



BE 1200
L.120mm **7**



BE 1212
L.115mm **3**



BE 287
L.105mm **5**

- Livrées avec carré de 7 mm, goupille et joint téflon.
- Autres percements : carré de 6 ou 8 mm (à préciser).
- Autres finitions : nous consulter.

- Supplied with 6, 7 or 8 mm spindle. Fixed with pin and washer.
- Grubscrew and circlip fixing available on request.
- Other finish : please contact us.

- Mit einem 7 mm Viereck, Stifte und Verbindung aus Teflon geliefert.
- Andere Bohrungen : « 6, 8 Viereck » (zum Notieren).
- Andere Fertigarbeiten : bitte fragen Sie uns.

Béquilles

Lever handles - Türklinken

BE1210 * **1 3 5 6 7** • L.140mm BE1200 * **1 3 5 6 7** • L.120mm BE1212 * **1 3 5 6 7** • L.115mm
BE287 * **1 3 5 6 7** • L.105mm

* **1** Noir/Black/Schwarz • **3** Poli verni/Pewter/Poliert lackiert • **5** Laiton massif/Brass/Vollmessing • **6** Rouillé ciré/Rust effect/Gerostet gebohnt • **7** Laiton vieilli/Antique brass/Geältert Messing



BE 271
L.100mm **5**



BE 265
L.110mm **7**



BE 261
L.100mm **3**



BE 1202
L.95mm **5**

- Livrées avec carré de 7 mm goupille et joint téflon.
- Autres percements : carré de 6 ou 8 mm (à préciser).
- Main droite ou gauche (à préciser).
- Autres finitions : nous consulter.



- Supplied with 6, 7 or 8 mm spindle. Fixed with pin and washer.
- Grubscrew and circlip fixing available on request.
- Handed left or right : please specify.
- Other finish : please contact us.



- Mit einem 7 mm Viereck, Stifte und Verbindung aus Teflon geliefert.
- Andere Bohrungen : « 6, 8 Viereck » (zum Notieren).
- Rechtshand oder Linkshand (zum Notieren).
- Andere Fertigarbeiten : bitte fragen Sie uns.

Béquilles

Lever handles - Türklinken

BE 271 * **1 3 5 6 7** • L.100mm BE 265 * **1 3 5 6 7** • L.110mm BE 261 * **1 3 5 6 7** • L.100mm
BE 1202 * **5 7** • L.95mm

* **1** Noir/Black/Schwarz • **3** Poli verni/Pewter/Poliert lackiert • **5** Laiton massif/Brass/Vollmessing • **6** Rouillé ciré/Rust effect/Gerostet gebohnt • **7** Laiton vieilli/Antique brass/Geältert Messing



Boutons de porte

Knobs sets - Türknöpfe

Boutons de porte/Door knobs/Türknöpfe

Boutons de condamnation/Turn and release knobs/Schließknöpfe



BT 288
H90mm **5**



BT 262
H86mm **7**



BT 302
H75mm **3**

- Livrés avec carré de 7 mm goupille et joint Teflon
- Autres percements : carré de 6 ou 8 mm (à préciser).
- Autres finitions : nous consulter.



- Supplied with 7 or 8 mm spindle (please specify).
- Circlip fixing available.



- Mit einem 7 mm Viereck, Stifte und Verbindung aus Teflon geliefert.
- Andere Bohrungen : « 6, 8 Viereck » (zum Notieren).
- Andere Fertigarbeiten : bitte fragen Sie uns.

Boutons de Porte

Door knobs - Türknöpfe

BT 262 * **1 3 5 6 7** • H86mm BT 288 * **1 3 5 6 7** • H90mm BT 302 * **1 3 6** • H75mm

* **1** Noir/Black/Schwarz • **3** Poli verni/Pewter/Poliert lackiert • **5** Laiton massif/Brass/Vollmessing • **6** Rouillé ciré/Rust effect/Gerostet gebohnt • **7** Laiton vieilli/Antique brass/Geältert Messing



BT 250
H85mm

3



BT 260
H87mm

1



BT 252
H85mm

5

- Livrés avec carré de 7 mm goupille et joint Téflon
- Autres percements : carré de 6 ou 8 mm (à préciser).
- Autres finitions : nous consulter.



- Supplied with 7 or 8 mm spindle (please specify).
- Circlip fixing available.



- Mit einem 7 mm Viereck Stifte und Verbindung aus Teflon geliefert.
- Andere Bohrungen : « 6, 8 Viereck » (zum Notieren).
- Andere Fertigarbeiten : bitte fragen Sie uns.

Boutons de Porte

Door knobs - Türknöpfe

BT250 * 1 3 5 6 7 • H85mm BT260 * 1 3 5 6 7 • H87mm BT252 * 1 3 5 6 7 • H85mm

* 1 Noir/Black/Schwarz • 3 Poli verni/Pewter/Poliert lackiert • 5 Laiton massif/Brass/Vollmessing • 6 Rouillé ciré/Rust effect/Gerostet gebohnt • 7 Laiton vieilli/Antique brass/Geältert Messing



BT 256
H72mm

5



BT 1014
H75mm



BT 292
H143mm

3



BT 290
H100mm

1



BT 254
H65mm

7

- Livrés avec carré de 7 mm goupille et joint Téflon
- Autres percements : carré de 6 ou 8 mm (à préciser).
- Autres finitions : nous consulter.



- Supplied with 7 or 8 mm spindle (please specify).
- Circlip fixing available.



- Mit einem 7 mm Viereck, Stifte und Verbindung aus Teflon geliefert.
- Andere Bohrungen : « 6, 8 Viereck » (zum Notieren).
- Andere Fertigarbeiten : bitte fragen Sie uns.

Boutons de Porte

Door knobs - Türknöpfe

BT 256 * 1 3 5 6 7 • H72mm BT 1014 * 1 3 5 6 7 • H75mm BT 292 * 1 3 6 • H143mm
 BT 290 * 1 3 6 • H100mm BT 254 * 1 3 5 6 7 • H65mm

* 1 Noir/Black/Schwarz • 3 Poli verni/Pewter/Poliert lackiert • 5 Laiton massif/Brass/Vollmessing •
 6 Rouillé ciré/Rust effect/Gerostet gebohnt • 7 Laiton vieilli/Antique brass/Geältert Messing



BT 266
H61mm

7



BT 274
H84mm

3



BT 1010
H65mm

5

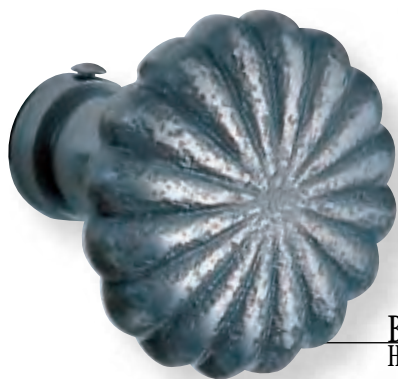

BT 273
H47mm

3



BT 280
H65mm

7

- Livrés avec carré de 7 mm
- Autres percements : carré de 6 ou 8 mm ou tige filetée (à préciser).
- Autres finitions : nous consulter.



- Supplied with 7 or 8 mm spindle (please specify).
- Circlip fixing available.



- Mit einem 7 mm Viereck geliefert.
- Andere Bohrungen : « 6, 8 Viereck » oder Schraubspindel (zum Notieren).
- Andere Fertigarbeiten : bitte fragen Sie uns.

Boutons de porte

Door knobs - Türknöpfe

BT 266 * 1 3 5 6 7 • H61mm BT 274 * 1 3 5 6 7 • H84mm BT 1010 * 5 7 • H65mm
 BT 273 * 1 3 5 6 7 • H47mm BT 280 * 1 3 5 6 7 • H65mm

* 1 Noir/Black/Schwarz • 3 Poli verni/Pewter/Poliert lackiert • 5 Laiton massif/Brass/Vollmessing •
 6 Rouillé ciré/Rust effect/Gerostet gebohnt • 7 Laiton vieilli/Antique brass/Geältert Messing



BT 276
H45mm

7



BT 264
H68mm

3



BT1002
H65mm

5

- Livrés avec carré de 7 mm goupille et joint Téflon
- Autres percements : carré de 6 ou 8 mm (à préciser).
- Autres finitions : nous consulter.



- Supplied with 7 or 8 mm spindle (please specify).
- Circlip fixing available.



- Mit einem 7 mm Viereck, Stifte und Verbindung aus Teflon geliefert.
- Andere Bohrungen : « 6, 8 Viereck » (zum Notieren).
- Andere Fertigarbeiten : bitte fragen Sie uns.

Boutons de Porte

Door knobs - Türknöpfe

BT276

* 1 3 5 6 7 • H45mm

BT264

* 1 3 5 6 7 • H68mm

BT1002

* 5 7 • H65mm

* 1 Noir/Black/Schwarz • 3 Poli verni/Pewter/Poliert lackiert • 5 Laiton massif/Brass/Vollmessing • 6 Rouillé ciré/Rust effect/Gerostet gebohntert • 7 Laiton vieilli/Antique brass/Geältert Messing



BT 258
H50mm **3**



BT 402
H80mm **5**



BT 286
H65mm **7**



BT 265
H61mm **5**



BT 358
H50mm **3**

- Livrés avec carré de 7 mm
- Autres percements : carré de 6 ou 8 mm (à préciser).
- Autres finitions : nous consulter.



- Supplied with 7 or 8 mm spindle (please specify).
- Circlip fixing available.



- Mit einem 7 mm Viereck geliefert.
- Andere Bohrungen : « 6, 8 Viereck » (zum Notieren).
- Andere Fertigarbeiten : bitte fragen Sie uns.

Boutons de Porte

Door knobs - Türknöpfe

BT258 * **1 3 5 6 7** • H50mm BT402 * **1 3 5 6 7** • H80mm BT286 * **1 3 5 6 7** • H65mm
 BT265 * **1 3 5 6 7** • H61mm BT358 * **1 3 5 6 7** • H50mm

* **1** Noir/Black/Schwarz • **3** Poli verni/Pewter/Poliert lackiert • **5** Laiton massif/Brass/Vollmessing •
6 Rouillé ciré/Rust effect/Gerostet gebohnt • **7** Laiton vieilli/Antique brass/Geältert Messing



BT 296
H40mm

5



BT 298
H46mm

3



BT 258 ter
H38mm

1



BT 300
H38mm

7

- Carré de 6 mm, long 40 mm et circlips
- A préciser :
lisse ou martelé excepté le BT 296 et le BT 298 uniquement martelé.

---><---

- 6 mm spindle, 40 mm length, c/w circlips

---><---

- Viereck von 6 mm, 40 mm lang und Sicherungsring
- Zum Notieren :
schlicht oder gehämmert nur nicht die Referenz BT 296 und BT 298 (nur gehämmert).

Boutons de Condamnation

Turn and release knobs - Schließknöpfe

BT 296 à cornes * 1 3 5 6 7 • H40mm BT 298 Louis XV * 1 3 5 6 7 • H46mm BT 258 ter Louis XIV * 1 3 5 6 7 • H38mm
BT 300 olive * 1 3 5 6 7 • H38mm

* 1 Noir/Black/Schwarz • 3 Poli verni/Pewter/Poliert lackiert • 5 Laiton massif/Brass/Vollmessing •
6 Rouillé ciré/Rust effect/Gerostet gebohnt • 7 Laiton vieilli/Antique brass/Geältert Messing



Plaques

Backplates - Platten

Plaques/Blackplates/Türbeschläge

Ensembles riv'bloc/Security bloc/Sicherheitblock



PE 349
H350 x 55 mm

3



PE 347
H280 x 35 mm

1



PE 329
H350 x 55 mm

5



PE 327
H270 x 35 mm

3

PE 1604
H240 x 27 mm

1

- Livrées avec kit de fixation
- Perçements
entraxe 70 mm (à préciser) :
 - non percée
 - bec de cane ○ - clé 🔑
 - cylindre européen 🔑
 - condamnation •
- Autres percements : 57 - 72 - 85 - 92 et 110 mm (sur demande).
- Autres finitions : nous consulter.

- Supplied with screws.
- Various lock centres and piercing (if any) available
 - blank
 - latch only ○
 - keyhole 🔑
 - European cylinder 🔑
 - turn and release •

- Mit einem Befestigungs-
kit geliefert.
- Lochabstand :
Bohrung 70 mm (zum Notieren) :
 - nicht gebohrt
 - Loch für Türklinke ○
 - Schlüssel 🔑
 - Profilzylinder 🔑
 - Abschluß •
- Andere Bohrungen : 57 - 72 - 85 - 92 und 110 mm (bitte fragen Sie uns).
- Andere Fertigarbeiten : bitte fragen Sie uns.

Plaques

Backplates - Platten

PE349 * 1 3 6 • H.350x55mm

PE347 * 1 3 6 • H.280x35mm

PE329 * 5 7 • H.350x55mm

PE327 * 1 3 5 6 7 • H.270x35mm

PE1604 * 1 3 5 6 7 • H.240x27mm

* 1 Noir/Black/Schwarz • 3 Poli verni/Pewter/Poliert lackiert • 5 Laiton massif/Brass/Vollmessing • 6 Rouillé ciré/Rust effect/Gerostet gebohrt • 7 Laiton vieilli/Antique brass/Geältert Messing



PE 359
H310 x 45 mm **1**



PE 359 bis
H280 x 34 mm **3**



PE 321
H267 x 43 mm **7**



PE 355
H270 x 45 mm **3**

- Livrées avec kit de fixation
- Percements
entraxe 70 mm (à préciser) :
 - non percée
 - bec de cane ○ - clé ⌧
 - cylindre européen ⌧
 - condamnation ◦
- Autres percements : 57 - 72 - 85 - 92 et 110 mm (sur demande).
- Autres finitions : nous consulter:

- Supplied with screws.
- Various lock centres and piercing (if any) available
 - blank
 - latch only ○
 - keyhole ⌧
 - European cylinder ⌧
 - turn and release ◦

- Mit einem Befestigungs-
kit geliefert.
- Lochabstand :
Bohrung 70 mm (zum Notieren) :
 - nicht gebohrt
 - Loch für Türklinke ○
 - Schlüssel ⌧
 - Profilylinder ⌧
 - Abschluß ◦
- Andere Bohrungen : 57 - 72 - 85 - 92 und 110 mm (bitte fragen Sie uns).
- Andere Fertigkeiten : bitte fragen Sie uns.

Plaques

Backplates - Platten

PE 359 * **1 3 6** • H 310 x 45 mm

PE 359 bis * **1 3 6** • H 280 x 34 mm

PE 321 * **1 3 5 6 7** • H 267 x 43 mm

PE 355 * **1 3 6** • H 270 x 45 mm



- Livrées avec kit de fixation
- Perçements
entraxe 70 mm (à préciser) :
 - non percée
 - bec de cane ○ - clé ☞
 - cylindre européen ☞
 - condamnation ◦
- Autres perçements : 57 - 72 - 85 - 92 et 110 mm (sur demande).
- Autres finitions : nous consulter.
- PE 315 et PE 325 : main droite ou gauche (à préciser).
←→←→←→
- Supplied with screws.
- Various lock centres and piercing (if any) available
 - blank
 - latch only ○
 - keyhole ☞
 - European cylinder ☞
 - tum and release ◦
- The product number PE 315 and PE 325 handed left or right (please specify).
←→←→←→
- Mit einem Befestigungs-
kit geliefert.
- Lochabstand :
Bohrung 70 mm (zum Notieren) :
 - nicht gebohrt
 - Loch für Türklinke ○
 - Schlüssel ☞
 - Profilylinder ☞
 - Abschluß ◦
- Andere Bohrungen : 57 - 72 - 85 - 92 und 110 mm (bitte fragen Sie uns).
- Andere Fertigarbeiten : bitte fragen Sie uns.
- Die Referenz PE 315 und PE 325 : rechtshand oder linkshand (zum Notieren).

Plaques

Backplates - Platten

PE 315 * 1 3 5 6 7 • H345x45mm PE 339 * 1 3 5 6 7 • H280x35mm PE 325 * 1 3 5 6 7 • H310x35mm



PE 341
H346x60mm

3

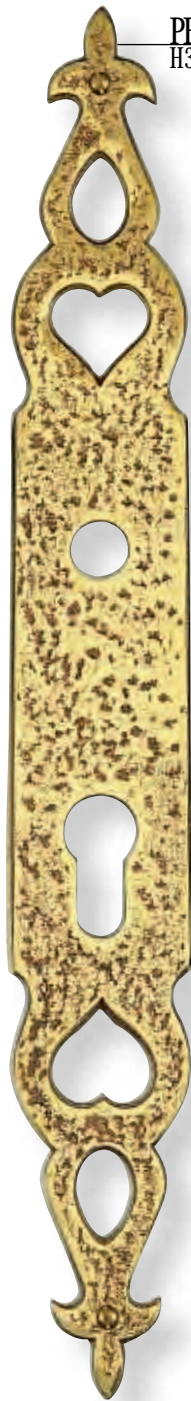

PE 353
H345x45mm

5



PE 333
H330x50mm

3



PE 357
H300x45mm

5

- Livrées avec kit de fixation
- Percements
entraxe 70 mm (à préciser) :
 - non percée
 - bec de cane ○ - clé ⌧
 - cylindre européen ⌧
 - condamnation ○
- Autres percements : 57 - 72 - 85 - 92 et 110 mm (sur demande).
- Autres finitions : nous consulter:



- Supplied with screws.
- Various lock centres and piercing (if any) available
 - blank
 - latch only ○
 - keyhole ⌧
 - European cylinder ⌧
 - turn and release ○



- Mit einem Befestigungs-
kit geliefert.
- Lochabstand :
Bohrung 70 mm (zum Notieren) :
 - nicht gebohrt
 - Loch für Türklinke ○
 - Schlüssel ⌧
 - Profilzylinder ⌧
 - Abschluß ○
- Andere Bohrungen : 57 - 72 - 85 - 92 und 110 mm (bitte fragen Sie uns).
- Andere Fertigarbeiten : bitte fragen Sie uns.

Plaques

Backplates - Platten

PE 341

* 1 3 6 • H346x60mm

PE 353

* 1 3 5 6 7 • H345x45mm

PE 333

* 1 3 5 6 7 • H330x50mm

PE 357

* 1 3 5 6 7 • H300x45mm



PE 335
H300x40mm **7**



PE 361
H220x25mm **3**



PE 1603
H260x27mm **3**



5 PE 335 ter
H220x35mm



5 PE 1602
H215x27mm



7 PE 323
H305x35mm

- Livrées avec kit de fixation
 - Perçements
entraxe 70 mm (à préciser) :
- non percée
- bec de cane ○ - clé ⌧
- cylindre européen ⌧
- condamnation ○
 - Autres perçements : 57 - 72 - 85 - 92 et 110 mm (sur demande).
 - Finitions : lisse ou martelée (à préciser).
 - Autres finitions : nous consulter.
-
- Supplied with screws.
 - Various lock centres and piercing (if any) available
- blank
- latch only ○
- keyhole ⌧
- European cylinder ⌧
- turn and release ○
-
- Mit einem Befestigungs-
kit geliefert.
 - Lochabstand : Bohrung 70 mm (zum Notieren) :
- nicht gebohrt
- Loch für Türklinke ○
- Schlüssel ⌧
- Profilzylinder ⌧
- Abschluß ○
 - Andere Bohrungen : 57 - 72 - 85 - 92 und 110 mm (bitte fragen Sie uns).
 - Fertigarbeiten : schlicht oder gehämmert (bitte fragen Sie uns).
 - Andere Fertigarbeiten : bitte fragen Sie uns.

Plaques

Backplates - Platten

PE 335	* 1 3 5 6 7 • H300x40mm	PE 361	* 1 3 5 6 7 • H220x25mm	PE 1603	* 1 3 5 6 7 • H260x27mm
PE 335 ter	* 1 3 5 6 7 • H220x35mm	PE 1602	* 1 3 5 6 7 • H215x27mm	PE 323	* 1 3 5 6 7 • H305x35mm

* **1** Noir/Black/Schwarz • **3** Poli verni/Pewter/Poliert lackiert • **5** Laiton massif/Brass/Vollmessing • **6** Rouillé ciré/Rust effect/Gerostet gebohrt • **7** Laiton vieilli/Antique brass/Geältert Messing



PE 327
H270 x 35mm **3**



PE 1604
H240 x 27mm **5**



PE 1602 martelée
H215 x 27mm **7**



PE 1601
H220 x 27mm **3**

PE 1602 lisse - smooth - schlicht
H215 x 27mm **5**



- Livrées avec kit de fixation
- Perçements
entraxe 70 mm (à préciser) :
- non percée
- bec de cane ○ - clé ☞
- cylindre européen ☞
- condamnation ○
- Autres percements : 57 - 72 - 85
- 92 et 110 mm (sur demande).
- Fixation 195 mm : Vis relieur
ou 3 x 16 (à préciser).
- Autres finitions : nous consulter.



- Supplied with screws.
- Various lock centres and piercing (if any) available
- blank
- latch only ○
- keyhole ☞
- European cylinder ☞
- turn and release ○
- 195 mm fixing (please contact us for type of fixing).



- Mit einem Befestigungs-
kit geliefert.
- Lochabstand :
Bohrung 70 mm (zum Notieren) :
- nicht gebohrt
- Loch für Türklinke ○
- Schlüssel ☞
- Profilzylinder ☞
- Abschluß ○
- Andere Bohrungen : 57 - 72 -
85 - 92 und 110 mm
(bitte fragen Sie uns).
- Befestigung 195 mm :
Verbindungsschraube oder 3 x 16
(zum Notieren).
- Andere Fertigarbeiten :
bitte fragen Sie uns.

Plaques

Backplates - Platten

PE 327 * **1 3 5 6 7** • H 270 x 35 mm

PE 1604 * **1 3 5 6 7** • H 240 x 27 mm

PE 1602 martelée * **1 3 5 6 7** • H 215 x 27 mm

PE 1602 lisse * **1 3 5 6 7** • H 215 x 27 mm

PE 1601 * **1 3 5 6 7** • H 220 x 27 mm

* **1** Noir/Black/Schwarz • **3** Poli verni/Pewter/Poliert lackiert • **5** Laiton massif/Brass/Vollmessing • **6** Rouillé ciré/Rust effect/Gerostet gebohntert • **7** Laiton vieilli/Antique brass/Geältert Messing

5 Boîtier Riv'Bloc 1704
H.265 x 60 x 17mm

5 BE 1204
L.123mm



5 PE 1706
H.265 x 60 x 13mm

- Livrées avec kit de fixation
 - Percements (à préciser) :
 - bec de cane ○ - clé ☞
 - cylindre européen ☞
 - Autres percements : nous consulter.
 - BE 1204 : main gauche ou droite (à préciser).
-
- Fixing supplied
 - Fixing (please specify):
 - Latch ○
 - keyhole ☞
 - European cylinder ☞
 - Other fixing please contact us.
 - BE 1204: handed left or right (please specify).
-
- Mit einem Befestigungs kit geliefert.
 - Bohrung (zum Notieren) :
 - Loch für Türklinke ○
 - Schlüssel ☞
 - Profilzylinder ☞
 - Andere Bohrungen : bitte fragen Sie uns.
 - BE 1204 : Linkshand oder Rechtshand (zum Notieren).

Ensembles Riv'Bloc

Security bloc - Sicherheitblock

Boîtier Riv'Bloc 1704

* 5 7 PE1706
• H 265 x 60x17mm

* 5 7 BE1204

• H 265 x 60x13mm

L.123mm* 5 7

5

Boîtier Riv'Bloc 1708
H265 x 60 x 17mm

5

BE 277 lisse
L115 mm

5

PE 1710
H265 x 60 x 13mm



- Livrées avec kit de fixation
- Percements (à préciser) :
 - bec de cane ○ - clé ☞
 - cylindre européen ☞
- Autres percements : nous consulter.
- BE 277 : main droite ou gauche (à préciser).

- Fixing supplied
- Fixing (please specify):
 - Latch ○
 - keyhole ☞
 - European cylinder ☞
- Other fixings: please contact us.
- BE 277: handed left or right (please specify).

- Mit einem Befestigungs-Kit geliefert.
- Bohrung (zum Notieren) :
 - Loch für Türklinke ○
 - Schlüssel ☞
 - Profilzylinder ☞
- Andere Bohrungen: bitte fragen Sie uns.
- BE 277: Rechtshand oder Linkshand (zum Notieren).

Ensembles Riv'Bloc

Security bloc - Sicherheitblock

Boîtier Riv'Bloc 1708

* 5 7 PE1710
• H 265 x 60x17mm

* 5 7 BE277 lisse
• H 265 x 60x13mm

L115 mm * 5 7



Entrées

Escutcheons - Eingänge

Entrées de porte/Door escutcheons/Türeingänge

Entrées de meuble/Cabinet escutcheons/Möbeleingänge



E 48
H 65 x 37 mm **5**



E 98
H 31 x 24 mm **3**



E 58
H 44 x 36 mm **3**



E 46
H 45 x 25 mm **7**



E 62
H 35 x 35 mm **3**

- Livrées avec visserie
- Les références E 58 et E 98 : clé uniquement
- Les références E 46 - E 48 et E62 : percements (à préciser).
 - non percée
 - bec de cane ○ - clé
 - cylindre européen
 - (excepté la réf E 46).
 - condamnation ○
- Autres percements : nous consulter.
- Autres finitions : nous consulter.

- Supplied with screws.
- Reference E58 and E98 available in keyhole only
- Reference E46-48 and E62: any piercing
 - blank
 - latch ○
 - keyhole
 - European cylinder
 - (except E46).
 - bathroom ○

- Mit Schrauben geliefert.
- Die Referenz E 58 und E 98 : Nur Schlüssel.
- Die Referenz E 46 - E 48 und E62 : Bohrungen : zum Notieren
 - nicht gebohrt
 - Loch für Türklinke ○
 - Schlüssel
 - Profilzylinder
 - (nur nicht E 46).
 - Abschluß ○
- Andere Bohrungen : bitte fragen Sie uns.
- Andere Fertigarbeiten : bitte fragen Sie uns.

Entrées

Escutcheons - Eingänge

E 48 * **1 3 5 6 7** • H 65 x 37 mm E 98 * **1 3 6** • H 31 x 24 mm E 58 * **1 3 5 6 7** • H 44 x 36 mm
 E 46 * **1 3 5 6 7** • H 45 x 25 mm E 62 * **1 3 5 6 7** • H 35 x 35 mm

* **1** Noir/Black/Schwarz • **3** Poli verni/Pewter/Poliert lackiert • **5** Laiton massif/Brass/Vollmessing • **6** Rouillé ciré/Rust effect/Gerostet gebohntert • **7** Laiton vieilli/Antique brass/Geältert Messing

7

R 326
Ø 70 mm



R 326 bis
martelée/antique/gehämmert
Ø 45 mm

3

3

R1504 lisse/smooth/Schlicht
Ø 55 mm



5

E 100 lisse/smooth/Schlicht
H 78 x 37 mm



- Livrées avec visserie.
- Perçages 6, 8 ou 10 mm (à préciser).
- Autres percements (à préciser) :
 - non percée
 - bec de cane
 - clé
 - cylindre européen
 - condamnation
- Finitions : lisse ou martelée (à préciser).
- Ref. E 100 : lisse uniquement.
- Autres finitions : (nous consulter).

- Supplied with screws.
- 6, 8 or 10 mm diameter : (please specify).
- Fixings (please specify)
 - blank
 - latch
 - keyhole
 - European cylinder
 - bathroom handle
- Product number E 100 : only smooth

- Mit schrauben geliefert.
- Bohrungen (zum notieren)
 - 6, 8, 10. Viereck
 - nicht gebohrt
 - Loch für Türklinke
 - Schlüssel
 - Profilzylinder
 - Abschluß
- Fertigarbeiten : schlicht oder gehämmert (zum Notieren)
- Die Referenz E 100 : nur schlicht.
- Andere Feitgarbeiten : bitte fragen Sie uns

Entrées

Escutcheons - Eingänge

R 326 * 1 3 5 6 7 • Ø 70 mm R1504 * 1 3 5 6 7 • Ø 55 mm E 100 * 1 3 5 6 7 • H 78 x 37 mm
 R 326 bis * 1 3 5 6 7 • Ø 46 mm

* 1 Noir/Black/Schwarz • 3 Poli verni/Pewter/Poliert lackiert • 5 Laiton massif/Brass/Vollmessing •
 6 Rouillé ciré/Rust effect/Gerostet gebohnt • 7 Laiton vieilli/Antique brass/Geältert Messing

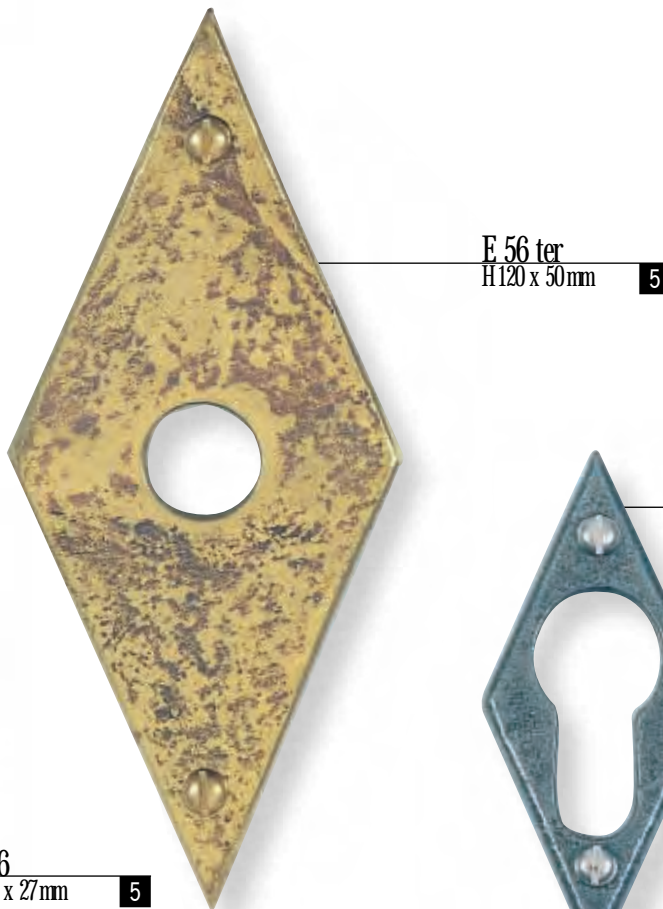
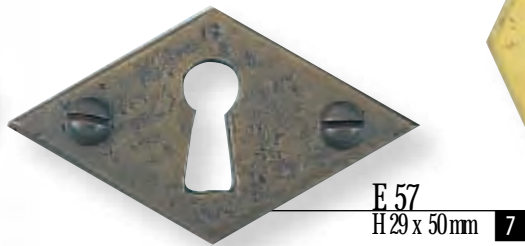
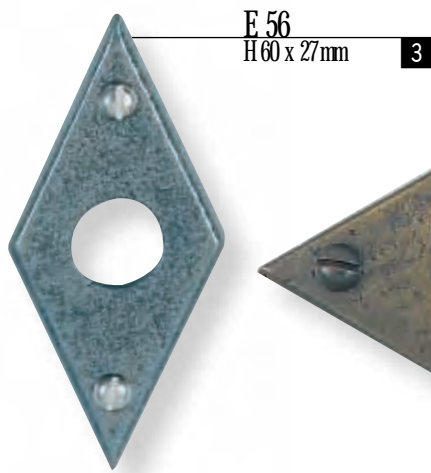

- Livrées avec visserie.
- Percements (à préciser) :
 - non percée
 - bec de cane ○ - clé ⌧
 - cylindre européen ⌧
 - condamnation ○
- Finitions : lisse ou martelée (à préciser).
- La référence E 57 : percement clé uniquement.
- Autres percements : nous consulter.



- Supplied with screws.
- Reference E56-E56ter and E1100 : any piercing.
 - blank
 - latch ○
 - keyhole ⌧
 - European cylinder ⌧
 - bathroom ○
- Reference E57
Only key



- Mit Schrauben geliefert.
- Bohrungen (zum Notieren) :
 - nicht gebohrt
 - Loch für Türklinke ○
 - Schlüssel ⌧
 - Profilylinder ⌧
 - Abschluß ○
- Fertigarbeiten : schlicht oder gehämmt (bitte fragen Sie uns).
- Die Referenz E 57 : Nur Schlüsselbohrung
- Andere Bohrungen : bitte fragen Sie uns.

Entrées

Escutcheons - Eingänge

E 56 * **1 3 5 6 7** • H 60 x 27mm E 57 * **1 3 5 6 7** • H 29 x 50mm E 1100 * **1 3 5 6 7** • H 70 x 30mm
E 56 ter * **1 3 5 6 7** • H 120 x 50mm

* **1** Noir/Black/Schwarz • **3** Poli verni/Pewter/Poliert lackiert • **5** Laiton massif/Brass/Vollmessing • **6** Rouillé ciré/Rust effect/Gerostet gebohnt • **7** Laiton vieilli/Antique brass/Geältert Messing

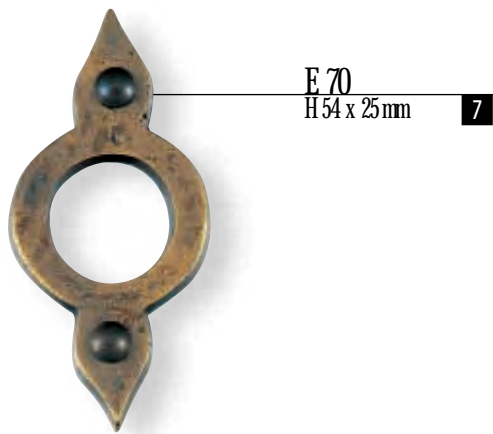

- Livrées avec visserie
- Finitions : lisse ou martelée (à préciser).



- Supplied with screws.



- Mit Schrauben geliefert.
- Fertigarbeiten : schlicht oder gehämmert (bitte fragen Sie uns).

Entrées

Escutcheons - Eingänge

E 70	* 1 3 5 6 7 • H 54 x 25 mm	E 64	* 1 3 5 6 7 • H 44 x 25 mm	E 68	* 1 3 5 6 7 • H 54 x 18 mm
E 67	* 1 3 5 6 7 • H 70 x 30 mm	E 66	* 1 3 5 6 7 • H 44 x 18 mm	E 70 bis	* 1 3 5 6 7 • H 54 x 25 mm
E 64 bis	* 1 3 5 6 7 • H 44 x 25 mm				

* 1 Noir/Black/Schwarz • 3 Poli verni/Pewter/Poliert lackiert • 5 Laiton massif/Brass/Vollmessing • 6 Rouillé ciré/Rust effect/Gerostet gebohntert • 7 Laiton vieilli/Antique brass/Geältert Messing

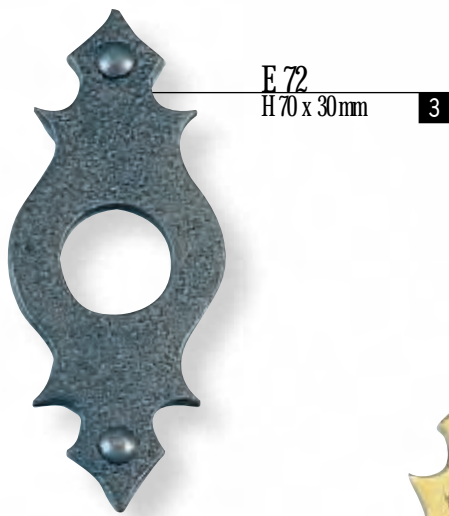

E.72
H 70 x 30mm

3



E.94
H 75 x 28mm

7



E.74
H 70 x 30mm

5



E.1101
H 75 x 30mm

7

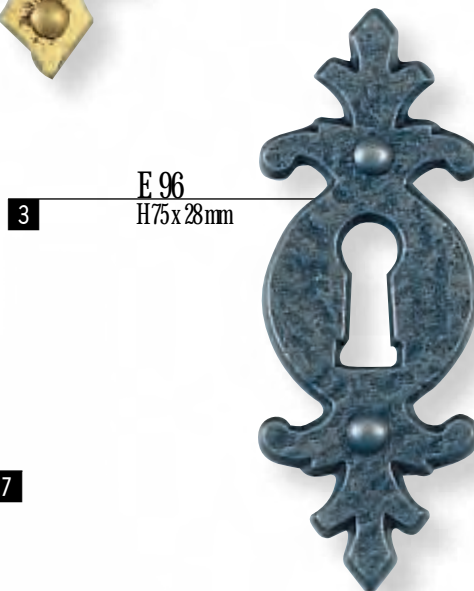

E.96
H 75 x 28mm

3

- Livrées avec visserie
- Perçements (à préciser) :
 - non percée
 - bec de cane ○
 - clé ⌒
 - cylindre européen ⌒
 - condamnation ○
- Autres perçements : nous consulter.
- Finitions : lisse ou martelée (à préciser).



- Supplied with screws
- Fixings (please specify):
 - blank
 - latch ○
 - keyhole ⌒
 - European cylinder ⌒
 - bathroom handle ○



- Mit Schrauben geliefert
- Bohrungen (zum Notieren) :
 - nicht gebohrt
 - Loch für Türklinke ○
 - Schlüssel ⌒
 - Profilzylinder ⌒
 - Abschluß ○
- Andere Bohrungen : bitte fragen Sie uns.
- Fertigarbeiten : schlicht oder gehämmert (bitte fragen Sie uns).

Entrées

Escutcheons - Eingänge

E.72 * 1 3 5 6 7 • H70x30mm

E.94 * 1 3 5 6 7 • H75x28mm

E.74 * 1 3 5 6 7 • H70x30mm

E.1101 * 1 3 5 6 7 • H75x30mm

E.96 * 1 3 5 6 7 • H75x28mm



R 1508 bdc
H 69 X 44 mm **1**



E 60 BDC
Ø 45 mm **3**



R 1508 clé
H 69 X 44 mm **3**



E 60 clé
Ø 45 mm **5**



R 1508 cyl
H 69 x 44 mm **6**



E 60 non percée
Ø 45 mm **6**

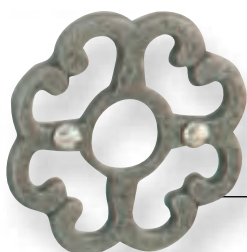

E 90
Ø 60 mm **3**

- Livrées avec visserie
- La référence E 90
Bec de cane uniquement
- Perçements (à préciser) :
 - non percée
 - bec de cane ○
 - clé ⌧
 - cylindre européen ⌧
 - condamnation ○
- Autres perçements :
nous consulter.
- Autres finitions :
nous consulter.

- Supplied with screws.
- The product number E 90
back plate c/w spindle hole
- Fixings (please specify):
 - blank
 - Latch ○
 - keyhole ⌧
 - European cylinder ⌧
 - bathroom handle ○

- Mit Schrauben geliefert
- Die referenz E 90
nur Loch für Türklinke
- Bohrungen (zum Notieren) :
 - nicht gebohrt
 - Loch für Türklinke ○
 - Schlüssel ⌧
 - Profilzylinder ⌧
 - Abschluß ○
- Andere Bohrungen :
bitte fragen Sie uns.
- Andere Fertigarbeiten :
bitte fragen Sie uns.

Entrées

Escutcheons - Eingänge

R 1508 bdc * **1 3 5 6 7** • H 69 X 44 mm E 60 clé * **1 3 5 6 7** • Ø 45 mm E 60 np * **1 3 5 6 7** • Ø 45 mm
 E 60 bdc * **1 3 5 6 7** • Ø 45 mm R 1508 cyl * **1 3 5 6 7** • H 69 X 44 mm E 90 Ø 60 mm * **1 3 5 6 7** • Ø 60 mm
 R 1508 clé * **1 3 5 6 7** • H 69 X 44 mm

* **1** Noir/Black/Schwarz • **3** Poli verni/Pewter/Poliert lackiert • **5** Laiton massif/Brass/Vollmessing •
6 Rouillé ciré/Rust effect/Gerostet gebohntert • **7** Laiton vieilli/Antique brass/Geältert Messing



- Livrées avec kit de fixation.
- Perçements : clé uniquement.



- Fixing supplied.
- Spindles : key only.



- Mit einem Befestigungs-
kit geliefert.
- Bohrungen : nur Schlüssel.

Entrées

Escutcheons - Eingänge

E84 * **1 3 5 6 7** • H 200 mm x 25 mm E82 * **1 3 5 6 7** • H 125 mm x 25 mm E86 * **1 3 5 6 7** • H 115 mm x 18 mm
 E81 * **1 3 5 6 7** • H 150 mm x 18 mm

* **1** Noir/Black/Schwarz • **3** Poli verni/Pewter/Poliert lackiert • **5** Laiton massif/Brass/Vollmessing •
6 Rouillé ciré/Rust effect/Gerostet gebohntert • **7** Laiton vieilli/Antique brass/Geältert Messing



Boutons de meuble

Cabinet Knobs - Möbelknöpfe



BT 258 bis
H 45mm

3



BT 267
Ø 47mm

3



BT 267 bis
Ø 40mm

5



BT 267 ter
Ø 32mm

7

- Livrés avec kit de fixation
- Percage : tige filetée M5.
- Finitions : lisse ou martelée (à préciser).



- Supplied with M5 fixings.



- Mit einem Befestigungs-
kit geliefert.
- Bohrung : Schraubspindel
M5.
- Fertigarbeiten : schlicht oder
gehämmert (zum Notieren).

Boutons de Meuble

Cabinet knobs - Möbelknöpfe

BT 258 bis

* 1 3 5 6 7 • H45mm

BT 267

* 1 3 5 6 7 • Ø47mm

BT 267 bis

* 1 3 5 6 7 • Ø40mm

BT 267 ter

* 1 3 5 6 7 • Ø32mm

* 1 Noir/Black/Schwarz • 3 Poli verni/Pewter/Poliert lackiert • 5 Laiton massif/Brass/Vollmessing •
6 Rouillé ciré/Rust effect/Gerostet gebohnt • 7 Laiton vieilli/Antique brass/Geältert Messing



- Livrés avec kit de fixation
- Percage : tige filetée M5.
- Finitions : lisse ou martelée (à préciser).

- Supplied with M5 fixings.

- Mit einem Befestigungsset geliefert.
- Bohrung : Schraubspindel M5.
- Fertigarbeiten : schlicht oder gehämmert (zum Notieren).

Boutons de Meuble

Cabinet knobs - Möbelknöpfe

BT 270 * 1 3 5 6 7 • H.35mm BT 268 * 1 3 5 6 7 • Ø40mm BT 272 * 1 3 5 6 7 • Ø30mm
 BT 294 * 1 3 5 6 7 • H.37mm BT 270 bis * 1 3 5 6 7 • Ø23mm

* 1 Noir/Black/Schwarz • 3 Poli verni/Pewter/Poliert lackiert • 5 Laiton massif/Brass/Vollmessing •
 6 Rouillé ciré/Rust effect/Gerostet gebohnt • 7 Laiton vieilli/Antique brass/Geältert Messing



BT 269
Ø 38mm

3



BT 304
Ø 38mm

5



BT 304 bis
Ø 30mm

7

- Livrés avec kit de fixation
- Percage : tige filetée M5.
- Finitions : lisse ou martelée (à préciser).



- Supplied with M5 fixings.



- Mit einem Befestigungs-
kit geliefert.
- Bohrung : Schraubspindel
M5.
- Fertigarbeiten : schlicht oder
gehämmert (zum Notieren).

Boutons de Meuble

Cabinet knobs - Möbelknöpfe

BT 269 * 1 3 5 6 7 • Ø38mm BT 304 * 1 3 5 6 7 • Ø38mm BT 304 bis * 1 3 5 6 7 • Ø30mm

* 1 Noir/Black/Schwarz • 3 Poli verni/Pewter/Polierlackiert • 5 Laiton massif/Brass/Vollmessing •
6 Rouillé ciré/Rust effect/Gerostet gebohnt • 7 Laiton vieilli/Antique brass/Geältert Messing



Clenches Verrous

Latches - Drücker
Bolts - Riegel

Verrous/Bolts/Riegel

Clenches/Latches/Drücker

Loquet poussier/Türfallklinke

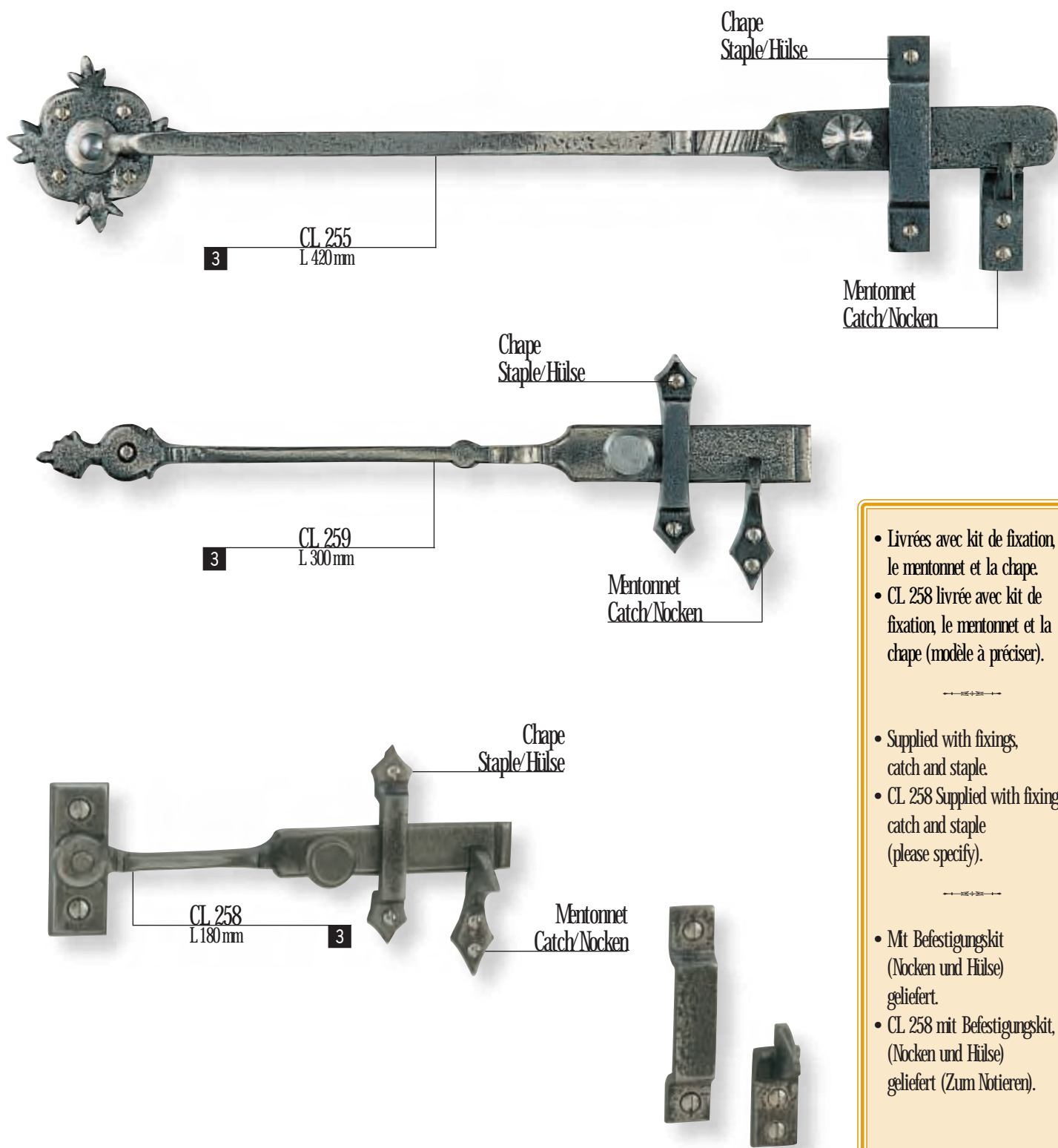

- Livrées avec kit de fixation, le mentonnet et la chape.
- CL 258 livrée avec kit de fixation, le mentonnet et la chape (modèle à préciser).

- Supplied with fixings, catch and staple.
- CL 258 Supplied with fixings, catch and staple (please specify).

- Mit Befestigungs kit (Nocken und Hülse) geliefert.
- CL 258 mit Befestigungs kit, (Nocken und Hülse) geliefert (Zum Notieren).

Clenches

Latches - Drücker

CL 255* 1 3 5 6 7 • Long. totale 420 mm

CL 259* 1 3 5 6 7 • Long. totale 300 mm

CL 258 * 1 3 6 • Long. totale 180 mm

* 1 Noir/Black/Schwarz • 3 Poli verni/Pewter/Poliert lackiert • 5 Laiton massif/Brass/Vollmessing • 6 Rouillé ciré/Rust effect/Gerostet gebohntert • 7 Laiton vieilli/Antique brass/Geältert Messing



V7
H390 x 50mm **7**



V5
H250 x 50mm **5**



V3
H120 x 40mm **3**

- Livrés avec kit de fixation
- Réf V7 : livré avec gâche du haut (GHV 5) et le conduit (COV 7). Possibilité avec gâche du bas (GBV 5). A préciser à la commande.
- Réf V5 : livré avec gâche du bas (GBV 5). Possibilité avec gâche du haut (GHV 5). A préciser à la commande.
- Réf V3 : livré avec gâche (photo).

- Supplied with fixings.
- Product number V7: supplied with GHV 5 and COV 7 guide. Available with mortice keeps (GBV 5). Please specify.
- Product number V5: supplied with GBV 5. Available with GHV 5. Please specify.
- Product number V3: supplied with mortice keep (see picture).

- Mit einem Befestigungs-
kit geliefert.
- Referenz V7 : mit
Oberschließklappe (GHV 5)
und Kanalführung (COV 7)
geliefert. Möglichkeit mit der
Unterschließklappe (GBV 5).
Zum Notieren auf die
Bestellung
- Referenz V5 : mit
Unterschließklappe (GBV 5).
Möglichkeit mit der
Oberschließklappe (GHV 5).
Zum Notieren auf die
Bestellung
- Referenz V3 : mit
Schließklappe (Photo) geliefert.

Verrous

Bolts - Riegel

V7 * **1 3 5 6 7** • H.390 x 50 mm V5 * **1 3 5 6 7** • H.250 x 50 mm V3 * **1 3 6** • H.120 x 40 mm

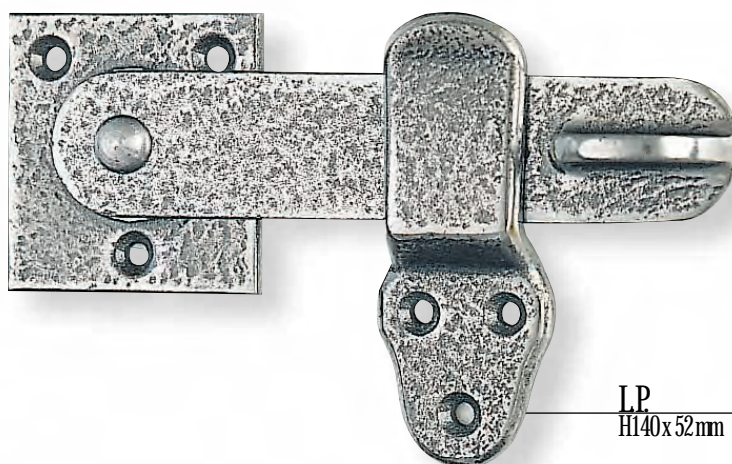

LP
H140x52mm

3

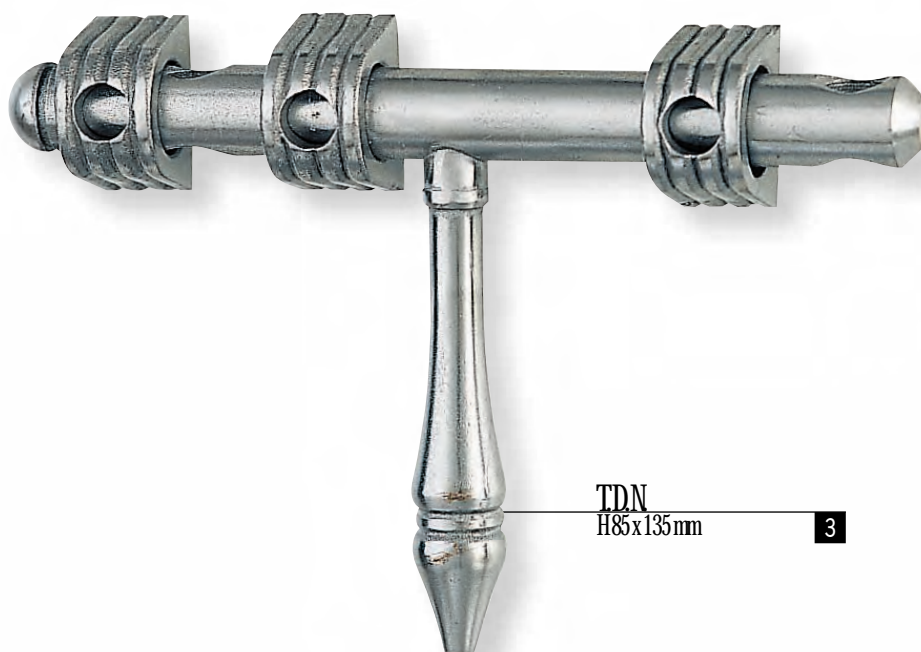

TDN
H85 x 135 mm

3

- Livrés avec kit de fixation
- L.P. : loquet de porte
- T.D.N. : tour de Nesle



- Fixing supplied
- L.P.: door check
- T.D.N.: tour de Nesle



- Mit einem Befestigungs-
kit geliefert
- L.P.: Türfallkinke
- T.D.N.: tour de Nesle

Verrous

Bolts - Riegel

LP * 1 3 6 • H140 x 52 mm TDN * 1 3 5 6 7 • H 85 x 135 mm

* 1 Noir/Black/Schwarz • 3 Poli verni/Pewter/Poliert lackiert • 5 Laiton massif/Brass/Vollmessing •
6 Rouillé ciré/Rust effect/Gerostet gebohntert • 7 Laiton vieilli/Antique brass/Geältert Messing

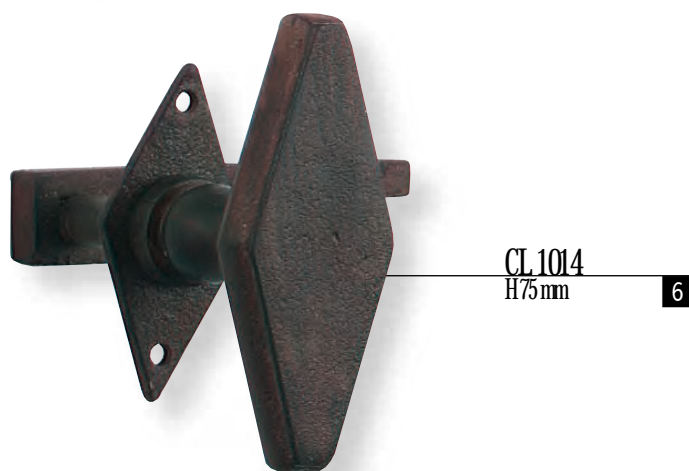
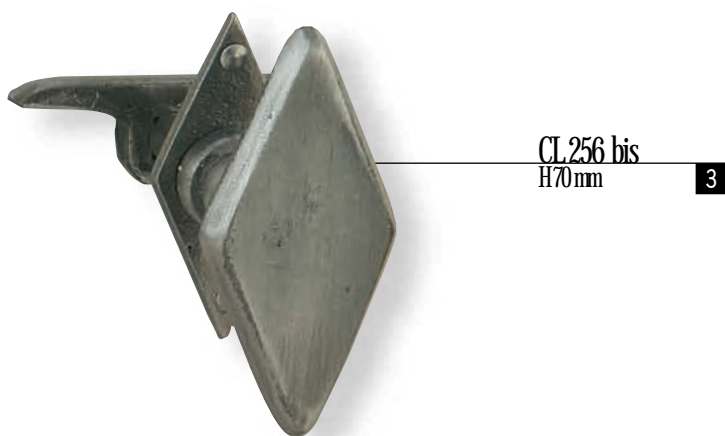

• CL. 254 bis, CL. 256 bis et CL. 1014 : livrées avec kit de fixation, entrée losange, tige écrou et bascule pour actionner la clenche.



• CL. 254 bis, CL. 256 bis and CL. 1014 : supplied with fixings, "losange" shape escutcheon, rod fixed with nut and accessories to operate the latch.



• CL. 254 bis, CL. 256 bis und CL. 1014 : mit einem Befestigungs kit geliefert, Eingänge "losange", Zubehör, das die Klinke antreibt.

Clenches

Latches - Drücker

CL. 254 bis * **1 3 5 6 7** • H61 mm CL. 256 bis * **1 3 5 6 7** • H70 mm CL. 1014 * **1 3 6** • H75 mm

* **1** Noir/Black/Schwarz • **3** Poli verni/Pewter/Poliert lackiert • **5** Laiton massif/Brass/Vollmessing • **6** Rouillé ciré/Rust effect/Gerostet gebohnt • **7** Laiton vieilli/Antique brass/Geältert Messing



CLP 258
H190mm

3



CLP 257
H267mm

3

- Livrées avec kit de fixation



- Fixing supplied



- Mit einem Befestigungs-
kit geliefert.

Clenches

Latches - Drücker

CLP 258

* 1 3 6 • H190mm

CLP 257

* 1 3 5 6 7 • H267mm

* 1 Noir/Black/Schwarz • 3 Poli verni/Pewter/Poliert lackiert • 5 Laiton massif/Brass/Vollmessing •
6 Rouillé ciré/Rust effect/Gerostet gebohntert • 7 Laiton vieilli/Antique brass/Geältert Messing



Targettes

Slide - Bolts / Drehriegel



T1401
H205 x 195 mm

3

- Livrée avec kit de fixation.
- Targette avec grande ou petite gâche (à préciser).



- Fixing supplied.
- Bolts can be supplied with small or large keeper (please specify).



- Mit Befestigungs kit geliefert.
- Drehriegel mit großer oder kleiner Schließklappe (Zum Notieren).

Targettes

Slide - Bolts / Drehriegel

T1401 petite gâche * 1 3 6 • H 205 x 150 mm T1401 grande gâche* 1 3 6 • H 205 x 195 mm

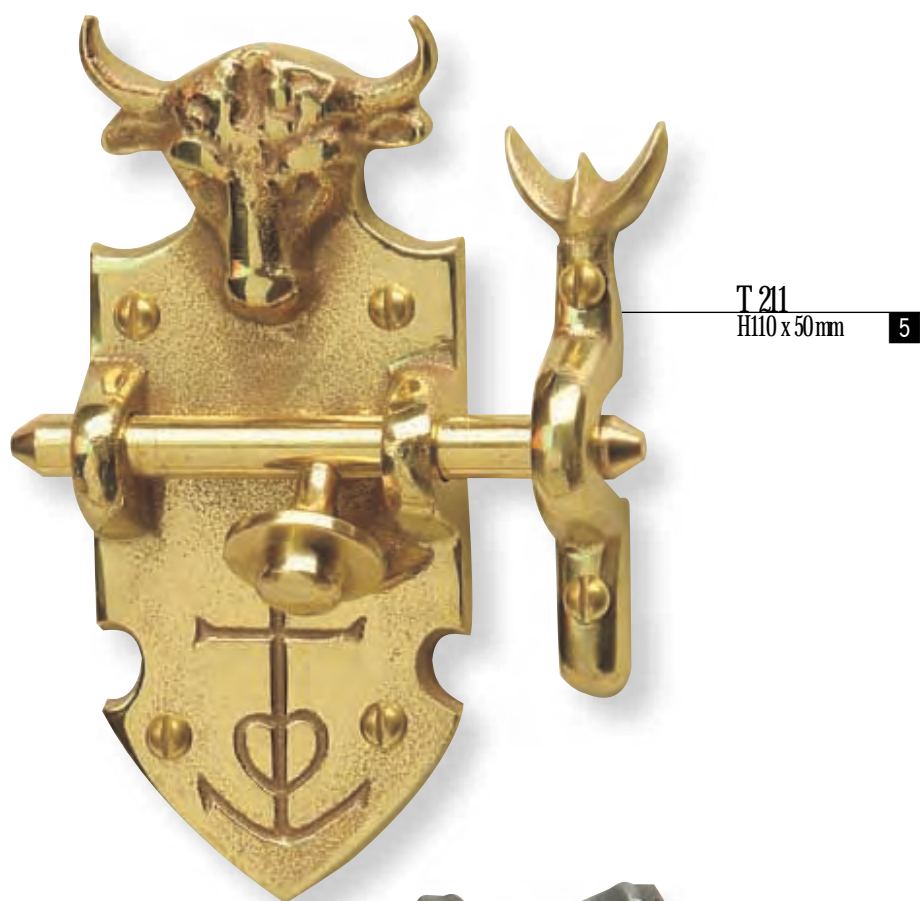

T 21
H110 x 50 mm **5**

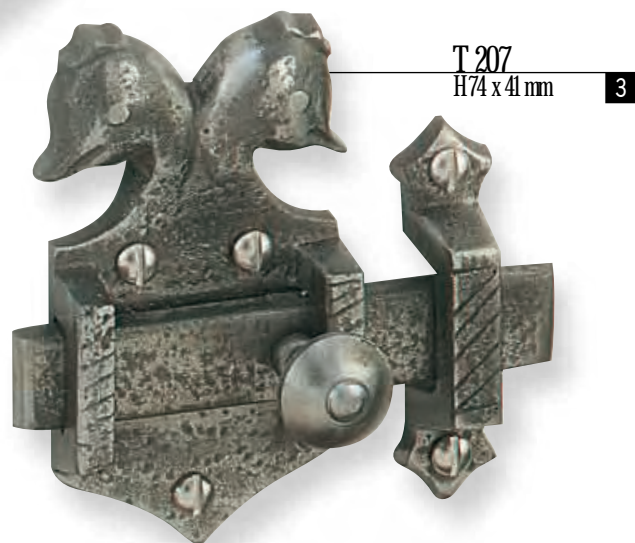

T 207
H74 x 41 mm **3**

- Livrées avec kit de fixation
- Fixing supplied
- Mit Befestigungs kit geliefert.

Targettes

Slide - Bolts / Drehriegel

T 211 Canards * **1 3 5 6 7** • H.110x50 mm

T 207 Canards * **1 3 6** • H.74 x 41 mm

* **1** Noir/Black/Schwarz • **3** Poli verni/Pewter/Poliert lackiert • **5** Laiton massif/Brass/Vollmessing • **6** Rouillé ciré/Rust effect/Gerostet gebohntert • **7** Laiton vieilli/Antique brass/Geältert Messing

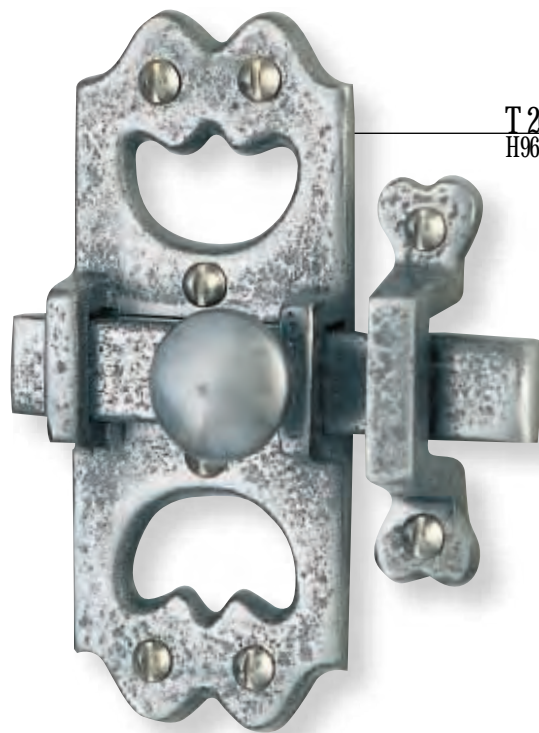

T 205
H96 x 41 mm **3**



T 217
H70 x 32 mm **5**



T 201
H85 x 34 mm **7**

- Livrées avec kit de fixation
--->>>---
- Fixing supplied
--->>>---
- Mit Befestigungs kit geliefert.

Targettes

Slide - Bolts / Drehriegel

T 205 Campagne * **1 3 6** • H 96 x 41 mm T 217 * **1 3 5 6 7** • H 70 x 32 mm T 201 * **1 3 5 6 7** • H 85 x 34 mm

* **1** Noir/Black/Schwarz • **3** Poli verni/Pewter/Poliert lackiert • **5** Laiton massif/Brass/Vollmessing •
6 Rouillé ciré/Rust effect/Gerostet gebohntert • **7** Laiton vieilli/Antique brass/Geältert Messing

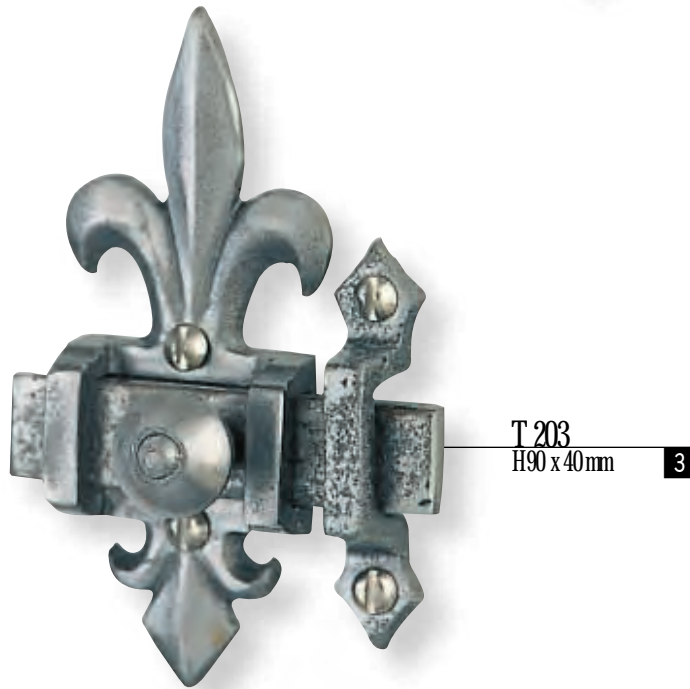
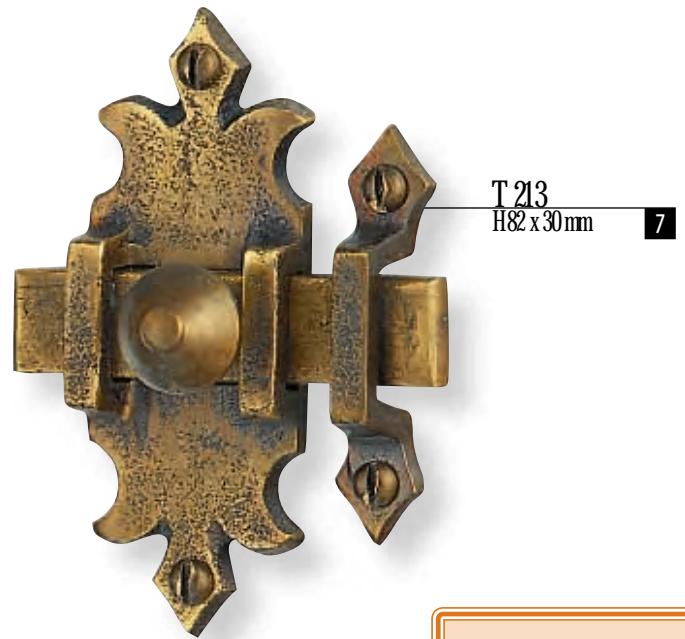
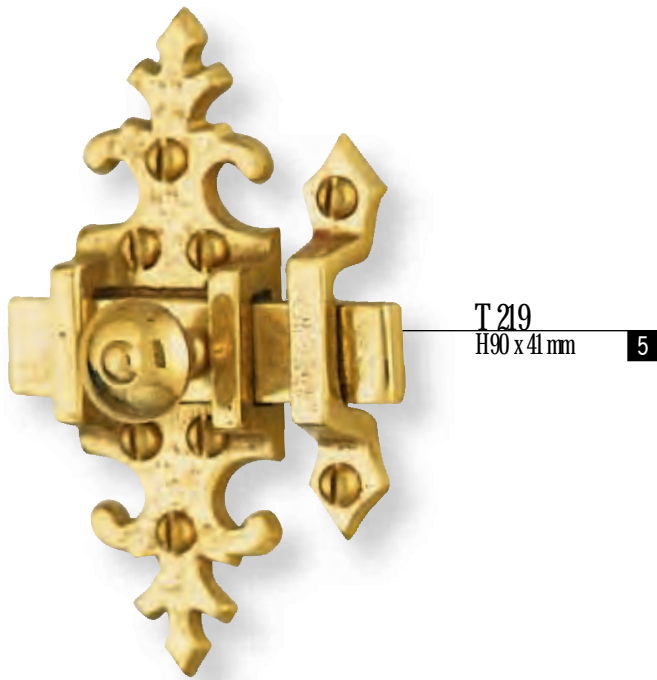

- Livrées avec kit de fixation
- Fixing supplied
- Mit Befestigungs kit geliefert.

Targettes

Slide - Bolts / Drehriegel

T 219 Rustique * **1 3 5 6 7** • H 90 x 41 mm T 213 * **1 3 5 6 7** • H 82 x 30 mm T 203 * **1 3 6** • H 90 x 40 mm

* **1** Noir/Black/Schwarz • **3** Poli verni/Pewter/Poliert lackiert • **5** Laiton massif/Brass/Vollmessing • **6** Rouillé ciré/Rust effect/Gerostet gebohntert • **7** Laiton vieilli/Antique brass/Geältert Messing



T 209
H152 x 55 mm **7**

T 215
H205 x 85 mm **3**

- Livrées avec kit de fixation
--->>>---
- Fixing supplied
--->>>---
- Mit Befestigungs kit geliefert.

Targettes

Slide - Bolts / Drehriegel

T 209 Grand siècle* **1 3 5 6 7** • H152 x 55 mm T 215 * **1 3 6** • H 205 x 85 mm

* **1** Noir/Black/Schwarz • **3** Poli verni/Pewter/Poliert lackiert • **5** Laiton massif/Brass/Vollmessing • **6** Rouillé ciré/Rust effect/Gerostet gebohntert • **7** Laiton vieilli/Antique brass/Geältert Messing



Crémones

Boutons de crémonne

Espagnolettes - Fensterriegel

Crémones pour porte-fenêtre/Windows espagnolettes/Fensterriegel

Boutons de Crémone pour fenêtre/Espagnolette knobs/Fiegelknöpfe

Platines pour fenêtre/Backplates/Platten für Fenster



BTC 258/PBTC 1
H65 x P 60mm

5



BTC 256/PBTC 1
H70 x P 60mm

3



BTC 254/PBTC 2
H70 x P 65mm

7



BTC 1014/PBTC 1
H75 x P 60mm

3



BTC 286/PBTC 1
H65 x P 60mm

5

- Posés à l'anglaise, entraxe 43 mm
- Livrés avec visserie et carré de 7 mm
- Présentations : avec PBTC 1 - PBTC 2 - PBTC 4 (à préciser).
- Finitions : lisse ou martelée (à préciser).



- Knobs with 43 mm
- Fixing centre
- Supplied with screws and 7 mm spindle (and sleeve if requested).
- Available as mix and match (please specify).



- Knöpfe englischerweise montiert Lochabstand 43 mm
- Mit Schrauben und Viereck von 7 mm
- Vorlegung : mit PBTC 1 - PBTC 2 - PBTC 4 (zum Notieren).
- Fertigarbeiten : schlicht oder gehämmert (bitte fragen Sie uns).

Boutons de Crémone

Espagnolette handles - Fensterriegel

BTC 258/PBTC 1

* 1 3 5 6 7
• H 65 x P 60 mm

BTC 256/PBTC 1

* 1 3 5 6 7
• H 70 x P 60 mm

BTC 254/PBTC 2

* 1 3 5 6 7
• H 70 x P 65 mm

BTC 1014/PBTC 1

* 1 3 6
• H 75 x P 60 mm

BTC 286/PBTC 1

* 1 3 5 6 7
• H 65 x P 60 mm

* 1 Noir/Black/Schwarz • 3 Poli verni/Pewter/Poliert lackiert • 5 Laiton massif/Brass/Vollmessing • 6 Rouillé ciré/Rust effect/Gerostet gebohntert • 7 Laiton vieilli/Antique brass/Geältert Messing



BTC 252/PBTC 1
H85 x P 65mm **7**

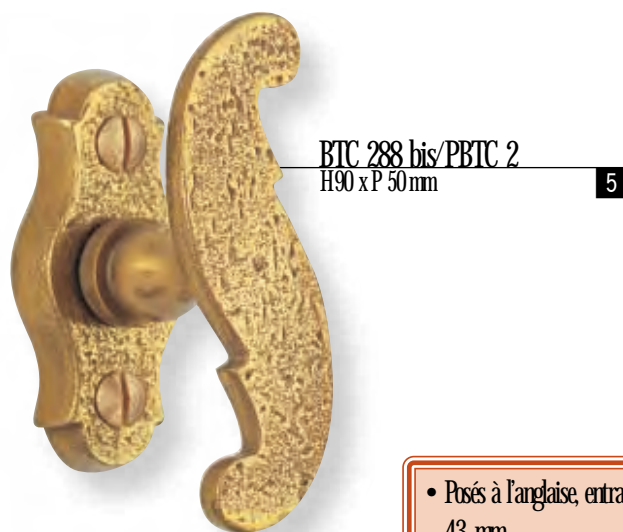

BTC 288 bis/PBTC 2
H90 x P 50mm **5**



BTC 250/PBTC 1
H85 x P 60mm **1**



BTC 262/PBTC 2
H85 x P 60mm **5**



BTC 260/PBTC 1
H90 x P 60mm **3**

- Posés à l'anglaise, entraxe 43 mm
- Livrés avec visserie et carré de 7 mm
- Présentations : avec PBTC 1 - PBTC 2 - PBTC 4 (à préciser).
- Finitions : lisse ou martelée (à préciser).



- Knobs with 43 mm
- Fixing centre
- Supplied with screws and 7 mm spindle (and sleeve if requested).
- Available as mix and match (please specify).



- Knöpfe englischerweise montiert Lochabstand 43 mm
- Mit Schrauben und Viereck von 7 mm
- Vorlegung : mit PBTC 1 - PBTC 2 - PBTC 4 (zum Notieren).
- Fertigarbeiten : schlicht oder gehämmert (bitte fragen Sie uns).

Boutons de Crémone

Espagnolette handles - Fensterriegel

BTC 252/PBTC 1 * **1 3 5 6 7**
H 85 x P 65 mm

BTC 288 bis/PBTC 2 * **1 3 5 6 7**
H 90 x P 50 mm

BT 250/PBTC 1 * **1 3 5 6 7**
H 85 x P 60 mm

BTC 262/PBTC 2 * **1 3 5 6 7**
H 85 x P 60 mm

BTC 260/PBTC 1 * **1 3 6**
H 90 x P 60 mm

* **1** Noir/Black/Schwarz • **3** Poli verni/Pewter/Poliert lackiert • **5** Laiton massif/Brass/Vollmessing • **6** Rouillé ciré/Rust effect/Gerostet gebohnt • **7** Laiton vieilli/Antique brass/Geältert Messing



R 1508
H 69 x 44 mm

6

BE 1212
L 115 mm

6

PBTC 2
H 70 x 33 mm

5

BE 277 ter
L 105 mm

5

PBTC 1
H 65 x 28 mm

7

BE 271
L 100 mm

7

PBTC 4
H 67 x 30 mm

3

BE 277 bis
L 115 mm

3

- Posés à l'anglaise, entraxe 43 mm
- Livrés avec visserie et carré de 7 mm
- Présentations : avec PBTC 1 - PBTC 2 - PBTC 4 (à préciser).
- Finitions : lisse ou martelée (à préciser).



- Knobs with 43 mm centre.
- Supplied with screws and 7 mm spindle.
- Complete : with PBTC 1 - PBTC 2 - PBTC 4 (please specify).
- Finish : smooth or antique (please specify).



- Knöpfe englischerweise montiert Lochabstand 43 mm
- Mit Schrauben und Viereck von 7 mm
- Vorlegung : mit PBTC 1 - PBTC 2 - PBTC 4 (zum Notieren).
- Fertigarbeiten : schlicht oder gehämmert (bitte fragen Sie uns).

Boutons de Crémone

Espagnolette handles - Fensterriegel

BE 1212/R 1508 * 1 3 6
L 115 mm/H 69 x 44 mm

BE 271/PBTC 1 * 1 3 5 6 7
L 100 mm/H 65 x 28 mm

BE 277 ter/PBTC 2 * 1 3 5 6 7
L 105 mm/H 70 x 33 mm

BE 277 bis/PBTC 4 * 1 3 5 6 7
L 115 mm/H 67 x 30 mm

* 1 Noir/Black/Schwarz • 3 Poli verni/Pewter/Poliert lackiert • 5 Laiton massif/Brass/Vollmessing • 6 Rouillé ciré/Rust effect/Gerostet gebohnt • 7 Laiton vieilli/Antique brass/Geältert Messing

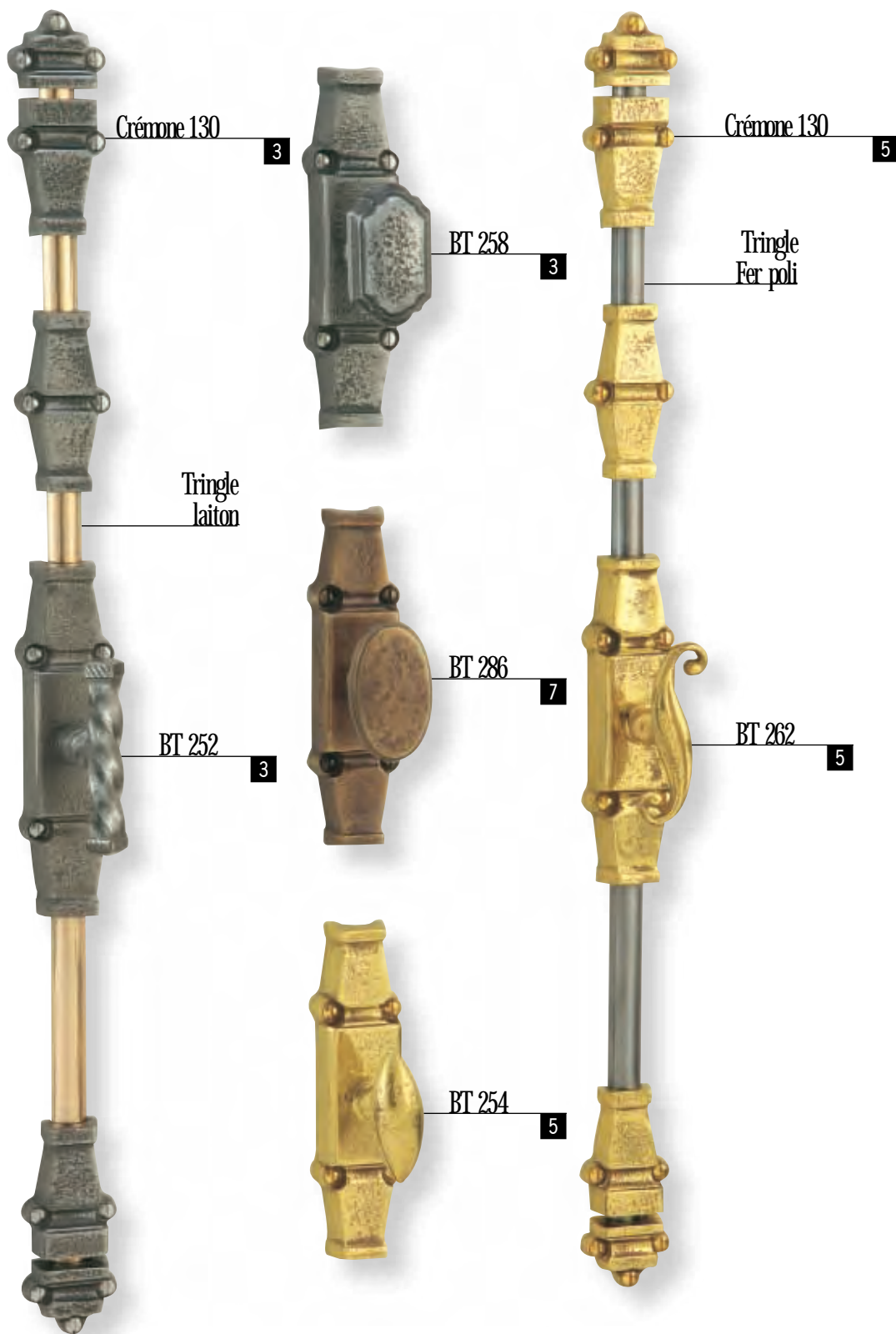

- Livrées avec visserie.
- Crémone 130: possibilité avec BT 252 - BT 254 - BT 258 - BT 262 - BT 286 (à préciser).
- Tringle laiton 2 m
- Tringle en acier poli 2 m ou 2,50 m (à préciser).

- Supplied with screws.
- Espagnolette 130: available with BT 252 - BT 254 - BT 258 - BT 262 - BT 286 (please specify).
- Brass bar 2 m
- Polished steelbar 2 m or 2 m 50 (please specify).

- Mit Schrauben.
- Fensterriegel 130: mit BT 252 - BT 254 - BT 258 - BT 262 - BT 286 (zum Notieren).
- Messingstange 2 m
- Polierter Stahlstange 2 m oder 2 m 50. (bitte fragen Sie uns).

Crémones

Espagnolette - Fensterriegel

Crémone 130* 1 3 5 6 7 • H160x40mm

* 1 Noir/Black/Schwarz • 3 Poli verni/Pewter/Poliert lackiert • 5 Laiton massif/Brass/Vollmessing • 6 Rouillé ciré/Rust effect/Gerostet gebohntert • 7 Laiton vieilli/Antique brass/Geältert Messing



PBTC 4
H 67 x 30 mm

3



PBTC 2
H 70 x 33 mm

5



PBTC 1
H 65 x 28 mm

3



CCR 14
H 165 x 40 mm

3



CCR 18
H 140 x 40 mm

5

- Livrées avec kit de fixation
Axe de fixation 43 mm



- Supplied with screws
• 43 mm fixing centre



- Mit einem Befestigungs-
kit geliefert.
Lochabstand 43 mm

Platines

Backplates - Platten

PBTC 4 * 1 3 5 6 7 • H 67 x 30 mm

PBTC 2 * 1 3 5 6 7 • H 70 x 33 mm

PBTC 1 * 1 3 5 6 7 • H 65 x 28 mm

CCR 14 * 1 3 5 6 7 • H 165 x 40 mm

CCR 18 * 1 3 5 6 7 • H 140 x 40 mm

* 1 Noir/Black/Schwarz • 3 Poli verni/Pewter/Poliert lackiert • 5 Laiton massif/Brass/Vollmessing •
6 Rouillé ciré/Rust effect/Gerostet gebohntert • 7 Laiton vieilli/Antique brass/Geältert Messing



Crémone 402/BT 402
H155 x 35 mm

7



BTC 402
H 80 x 26 mm

7

- Livrée avec kit de fixation
- BTC 402 : Axe de fixation 43 mm



- Fixing supplied
- BTC 402 43 mm fixing



- Mit einem Befestigungs-
kit geliefert.
- Lochabstand 43 mm

Crémones - Boutons de Crémones

Windows espagnolettes - Fensterriegel

Crémone 402/BT 402* 1 3 5 6 7 • H155 x 35 mm

BTC 402 * 1 3 5 6 7 • H80 x 26 mm

* 1 Noir/Black/Schwarz • 3 Poli verni/Pewter/Poliert lackiert • 5 Laiton massif/Brass/Vollmessing •
6 Rouillé ciré/Rust effect/Gerostet gebohrt • 7 Laiton vieilli/Antique brass/Geältert Messing



Entrées Poignées de meuble

Escutcheons - Handles
Eingänge - Möbelknöpfe

Entrées pour meuble/Cabinet escutcheons/Möbeleingänge

Poignées fixes/Cabinet pulls/Festgriffe

Poignées-attaches/Swan kneck cabinet pulls/Bandhänge

Poignées à encastrer/Flush handles/Griffe zum Einsetzen

Pendants/Drop handles/Gehänge

Anneaux de clé/Key rings/Schlüsselköpfe

Accessoires décoratifs : petites charnières, pentures pour meuble/

Decorative accessories : small hinges, hinge fronts/

Dekoratives Zubehör : kleine Scharniere, Möbeltürbander

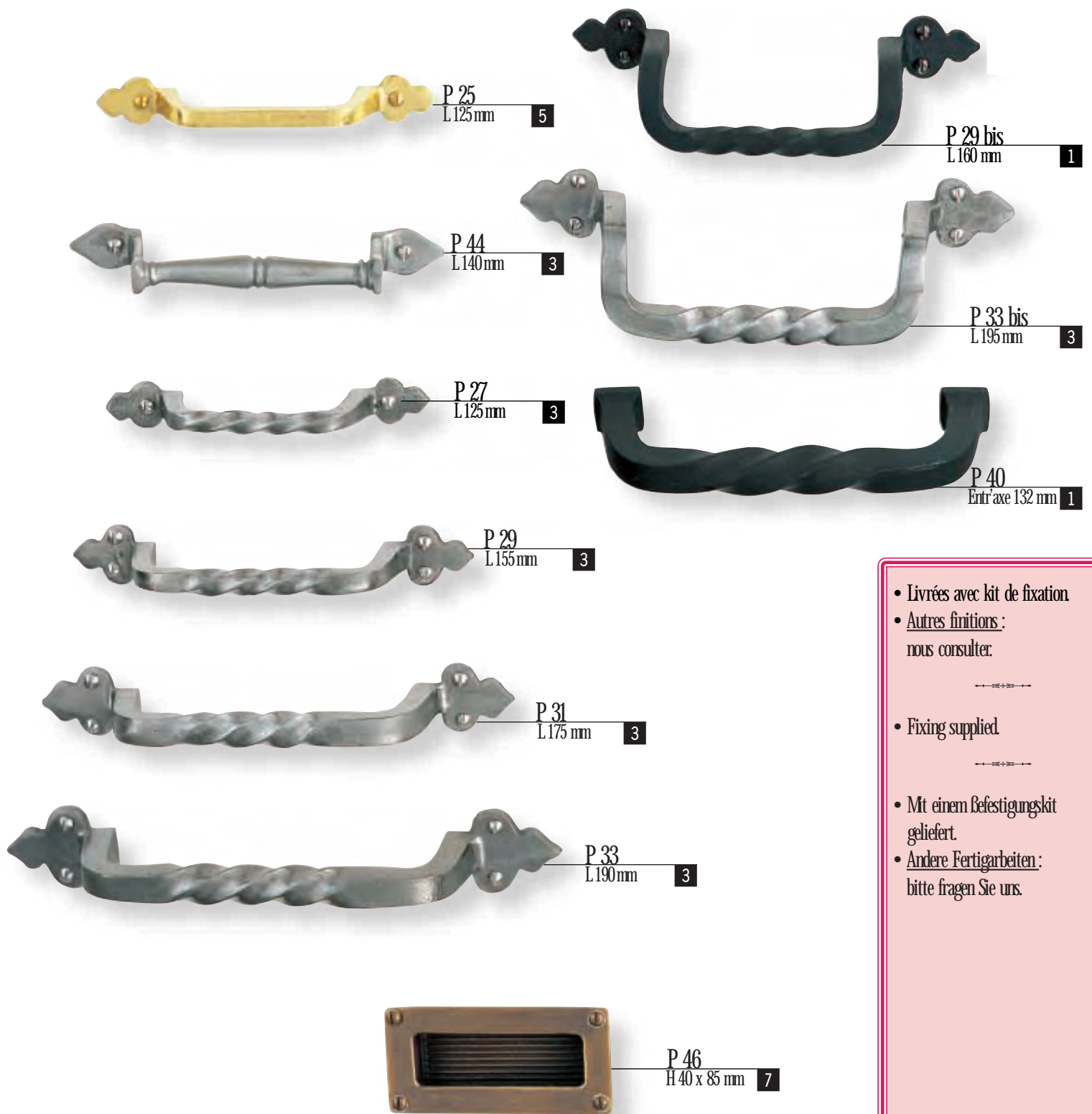

• Livrées avec kit de fixation
 • Autres finitions :
 nous consulter.

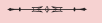

• Fixing supplied

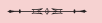

• Mit einem Befestigungs-
 kit geliefert.
 • Andere Fertigarbeiten :
 bitte fragen Sie uns.

Poignées

Cabinet Pulls - Festgriffe

P 25	* 1 3 5 6 7 • L.125 mm	P 31	* 1 3 6 • L.175 mm	P 40	* 1 3 6 • Entr'axe 132 mm
P 44	* 1 3 5 6 7 • L.140 mm	P 33	* 1 3 6 • L.190 mm	P 46	* 1 3 5 6 7 • H.40x85 mm
P 27	* 1 3 5 6 7 • L.125 mm	P 29 bis	* 1 3 6 • L.160 mm		
P 29	* 1 3 5 6 7 • L.155 mm	P 33 bis	* 1 3 6 • L.195 mm		

* 1 Noir/Black/Schwarz • 3 Poli verni/Pewter/Poliert lackiert • 5 Laiton massif/Brass/Vollmessing •



Pendant - Drop handles - Gehänge
H 75 mm

3



P1900
H 65 x 65 mm

3



PA 3
H 60 x 50 mm

5



PA 7
H 45 x 100 mm

7

- Livrées avec tige filetée M5.
- Autres finitions :
nous consulter.



- Supplied with dowel screws M5.



- Mit Schraubspindel M5 geliefert.
- Andere Fertigarbeiten :
bitte fragen Sie uns.

Poignées

Cabinet Pulls - Festgriffe

Pendant * 1 3 5 6 7 • H75mm P1900 * 1 3 5 6 7 • H65x65mm PA 3 * 1 3 5 6 7 • H60x50mm
PA 7 * 1 3 5 6 7 • H45x100mm

* 1 Noir/Black/Schwarz • 3 Poli verni/Pewter/Poliert lackiert • 5 Laiton massif/Brass/Vollmessing •
6 Rouillé ciré/Rust effect/Gerostet gebohnt • 7 Laiton vieilli/Antique brass/Geältert Messing



PA 14
L.110 mm

3



PA 15
L.110 mm

3



PA 16
L.115 mm

5

- Livrées avec tige filetée M4.
- Autres finitions :
nous consulter.



- Supplied with dowel screws M4.



- Mit Schraubspindel M4 geliefert.
- Andere Fertigarbeiten :
bitte fragen Sie uns.

Poignées

Cabinet Pulls - Festgriffe

PA 14 * 1 3 6 • L.110 mm PA 15 * 1 3 6 • L.110 mm PA 16 * 1 3 5 6 7 • L.115 mm

* 1 Noir/Black/Schwarz • 3 Poli verni/Pewter/Poliert lackiert • 5 Laiton massif/Brass/Vollmessing •
6 Rouillé ciré/Rust effect/Gerostet gebohnt • 7 Laiton vieilli/Antique brass/Geältert Messing



PM
L 280 mm **3**



PCC 1
H 85 x 70 mm **1**



PCR
H 67 x 73 mm **3**



P 42
H 190 x 65 mm **3**

• Livrées avec kit de fixation



• Fixing supplied



• Mit einem Befestigungs-
kit geliefert.

Charnières - Poignée

Hinges - Cabinet Pull - Scharniere - Festgriffe

PM * **1 3 6** • L 280mm PCR * **1 3 6** • H 67 x 73mm P 42 * **1 3 6** • H 190 x 65mm
PCC 1 * **1 3 6** • H 85 x 70mm

* **1** Noir/Black/Schwarz • **3** Poli verni/Pewter/Poliert lackiert • **5** Laiton massif/Brass/Vollmessing •
6 Rouillé ciré/Rust effect/Gerostet gebohnt • **7** Laiton vieilli/Antique brass/Geältert Messing



PAB 267
H70x218mm

7



PAB 267 bis
H40x140mm

1

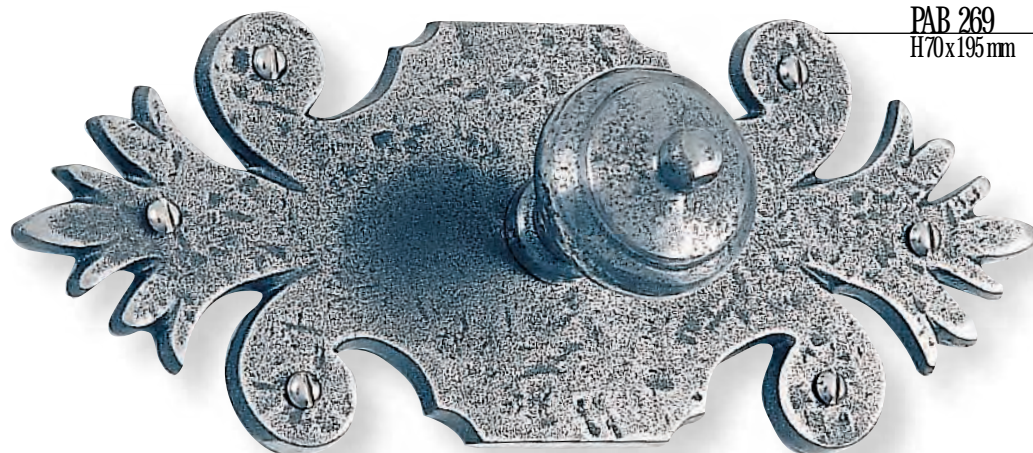

PAB 269
H70x195mm

3

- Livrées avec vis 3 x 16.



- Supplied with 3 x 16 screws.



- Mit 3 x 16 Schrauben geliefert.

Poignées

Cabinet Pulls - Festgriffe

PAB 267 * 1 3 5 6 7 • H70x218mm PAB 267bis * 1 3 5 6 7 • H40x140mm PAB 269 * 1 3 5 6 7 • H70x195mm

* 1 Noir/Black/Schwarz • 3 Poli verni/Pewter/Poliert lackiert • 5 Laiton massif/Brass/Vollmessing •
6 Rouillé ciré/Rust effect/Gerostet gebohntert • 7 Laiton vieilli/Antique brass/Geältert Messing



E 84
H 200 x 25 mm 5



E 81
H 150 x 18 mm 3



E 82
H 125 x 25 mm 5



E 86
H 115 x 18 mm 3

- Livrées avec kit de fixation
- Perçements : clé uniquement.



- Fixing supplied
- Spindles : key only.



- Mit einem Befestigungs-
kit geliefert.
- Bohrungen : nur Schlüssel.

Entrées

Escutcheons - Eingänge

E 84 * 1 3 5 6 7 • H 200x25mm E 81 * 1 3 5 6 7 • H 150x18mm E 82 * 1 3 5 6 7 • H 125x25mm
E 86 * 1 3 5 6 7 • H 115x18mm

* 1 Noir/Black/Schwarz • 3 Poli verni/Pewter/Poliert lackiert • 5 Laiton massif/Brass/Vollmessing •
6 Rouillé ciré/Rust effect/Gerostet gebohnt • 7 Laiton vieilli/Antique brass/Geältert Messing



E 50
H160x 30mm **3**



E 78
H90x 60mm **3**



E 92
H75x 45mm **7**



E 80
H60x 17mm **5**

- Livrées avec visserie
- Perçements : clé uniquement.



- Supplied with screws.
- Spindles : key only.



- Mit Schrauben geliefert.
- Bohrungen : nur Schlüssel.

Entrées

Escutcheons - Eingänge

E 50 * **1 3 6** • H160 mm x 30 mm E 78 * **1 3 6** • H 90 mm x 60 mm E 80 * **1 3 5 6 7** • H 60 mm x 17 mm
E 92 * **1 3 5 6 7** • H 75 mm x 45 mm

* **1** Noir/Black/Schwarz • **3** Poli verni/Pewter/Poliert lackiert • **5** Laiton massif/Brass/Vollmessing •
6 Rouillé ciré/Rust effect/Gerostet gebohnt • **7** Laiton vieilli/Antique brass/Geältert Messing



E.52
H30x73mm **1**



E.54
H28x145mm **5**

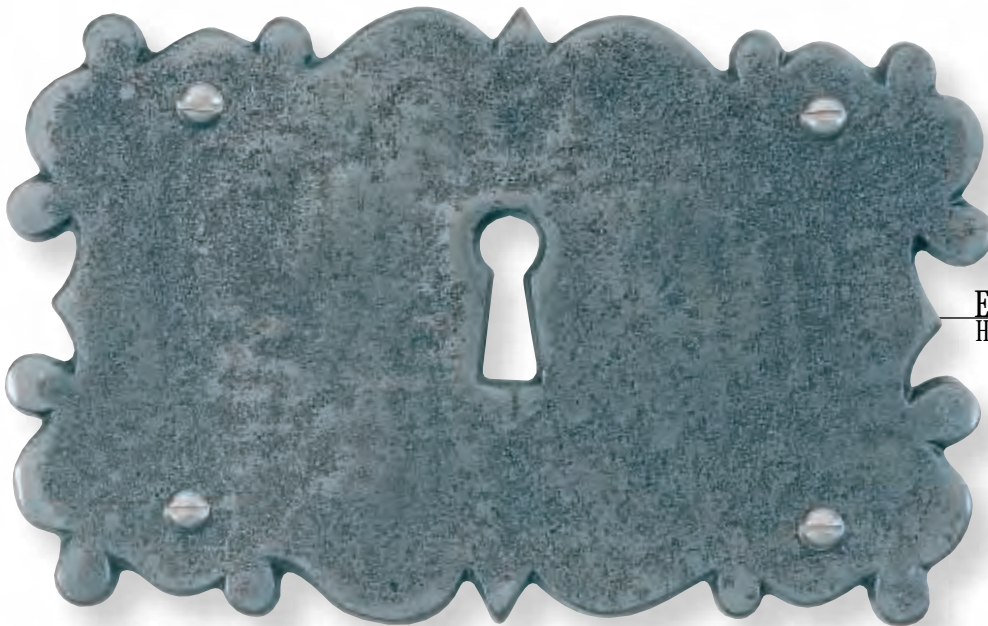

E.76
H80x130mm **3**

- Livrées avec kit de fixation
- Percements : clé uniquement.



- Fixing supplied
- Spindles : key only .



- Mit einem Befestigungs-
kit geliefert
- Bohrungen : nur Schlüssel.

Entrées

Escutcheons - Eingänge

E.52 * **1 3 5 6 7** • H.30 x 73 mm E.54 * **1 3 5 6 7** • H.28 x 145 mm E.76 * **1 3 6** • H.80 x 130 mm

* **1** Noir/Black/Schwarz • **3** Poli verni/Pewter/Poliert lackiert • **5** Laiton massif/Brass/Vollmessing • **6** Rouillé ciré/Rust effect/Gerostet gebohnt • **7** Laiton vieilli/Antique brass/Geältert Messing

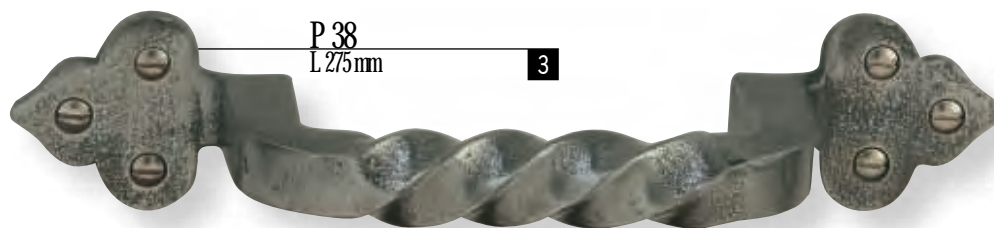
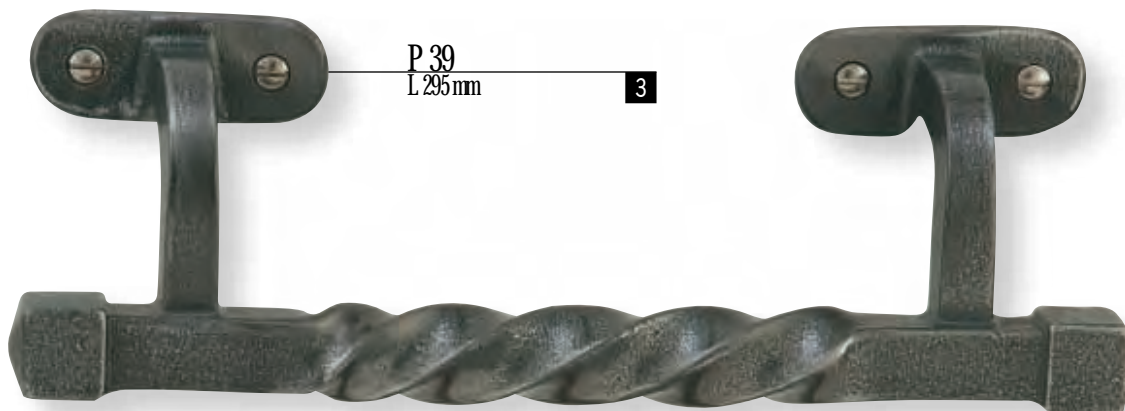

• Livrées avec kit de fixation



• Fixing supplied



• Mit einem Befestigungs-
kit geliefert.

Poignées

Cabinet Pulls - Festgriffe

P 39 * 1 3 5 6 7 • L. 295 mm P 38 * 1 3 5 6 7 • L. 275 mm

* 1 Noir/Black/Schwarz • 3 Poli verni/Pewter/Poliert lackiert • 5 Laiton massif/Brass/Vollmessing •
6 Rouillé ciré/Rust effect/Gerostet gebohnt • 7 Laiton vieilli/Antique brass/Geältert Messing



A 111
H 50 x 53 mm **3**



A 113
H 47 x 41 mm **3**



A 115
H 37 x 24 mm **3**



A 117
H 46 x 38 mm **3**



A 119
H 32 x 30 mm **3**



A 121
H 40 x 24 mm **3**

• Livrés non percés ou percés à 4 mm avec tige filetée et écrou (à préciser).



• Supplied blank or with 4 mm piercing (please specify).



• Nicht gebohrt oder gebohrt 4 mm mit einem Schraubspindel und Zubehör (zum Notieren).

Anneaux de clés

Key rings - Schlüsselköpfe

A 111	* 1 3 6 • H 50 x 53 mm	A 113	* 1 3 6 • H 47 x 41 mm	A 115	* 1 3 5 6 7 • H 37 x 24 mm
A 117	* 1 3 5 6 7 • H 46 x 38 mm	A 119	* 1 3 6 • H 32 x 30 mm	A 121	* 1 3 6 • H 40 x 24 mm

* **1** Noir/Black/Schwarz • **3** Poli verni/Pewter/Poliert lackiert • **5** Laiton massif/Brass/Vollmessing • **6** Rouillé ciré/Rust effect/Gerostet gebohnt • **7** Laiton vieilli/Antique brass/Geältert Messing

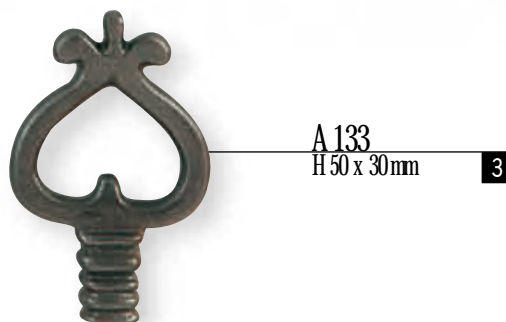
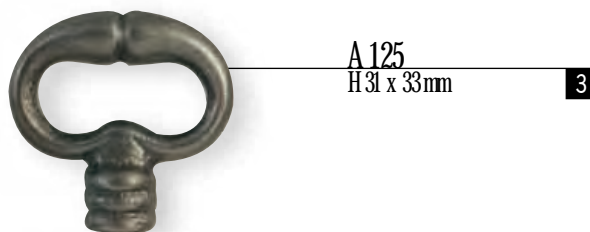
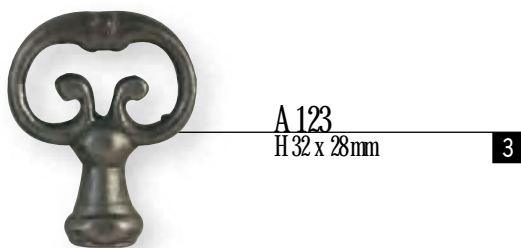

• Livrés non percés ou percés à 4 mm avec tige filetée et écrou (à préciser).

• Supplied blank or with 4 mm piercing (please specify).

• Nicht gebohrt oder gebohrt 4 mm mit einem Schraubspindel und Zubehör (zum Notieren).

Anneaux de clés

Key rings - Schlüsselköpfe

A 123	* 1 3 5 6 7 • H 32 x 28 mm	A 125	* 1 3 5 6 7 • H 31 x 33 mm	A 127	* 1 3 6 • H 40 x 30 mm
A 129	* 1 3 6 • H 40 x 28 mm	A 131	* 1 3 6 • H 40 x 38 mm	A 133	* 1 3 6 • H 50 x 30 mm
A 137	* 1 3 5 6 7 • H 47 x 35 mm				

* **1** Noir/Black/Schwarz • **3** Poli verni/Pewter/Poliert lackiert • **5** Laiton massif/Brass/Vollmessing • **6** Rouillé ciré/Rust effect/Gerostet gebohntert • **7** Laiton vieilli/Antique brass/Geältert Messing



Rosaces

Roses - Rosetten

Rosaces pour porte ou meuble/Cabinet roses/Für Tür oder Möbel



R.306
H70x70mm

1



R.320
D 55mm

3



R.316
H60x60mm

3



R.330
D58mm

3

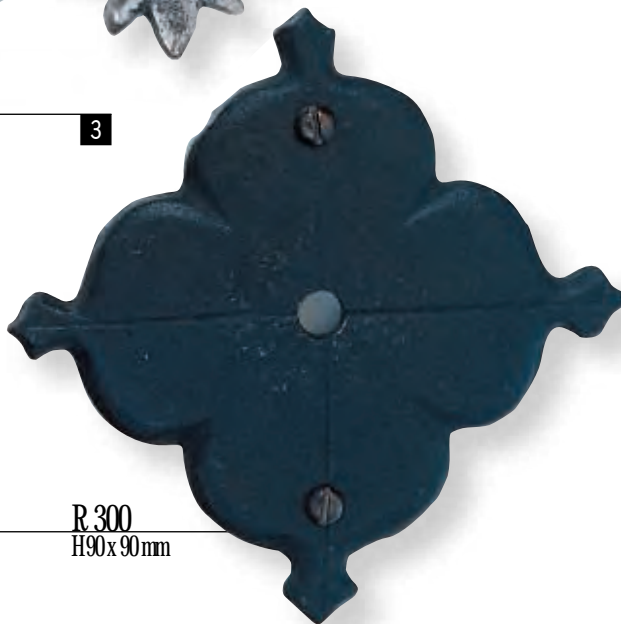

R.300
H90x90mm

1

- Livrées avec kit de fixation
- Perçages : 6, 8 ou 10 mm (à préciser).
- Autres percements : nous consulter.



- Supplied with screws.
- Spindles : 6, 8 or 10 mm diameter centre piercing (please contact us).



- Mit einem Befestigungs-
kit geliefert.
- Bohrungen : 6 - 8 oder 10 mm (zum Notieren).
- Andere Bohrungen : bitte fragen Sie uns.

Rosaces

Roses - Rosetten

R.306 * 1 3 6 • H70x70mm

R.320 * 1 3 5 6 7 • D.55mm

R.316 * 1 3 6 • H60x60mm

R.330 * 1 3 6 • D.58mm

R.300 * 1 3 5 6 7 • H90x90mm



R 334
Ø 105mm

7



R 336
Ø 100mm

1



R 328
Ø 60mm

5

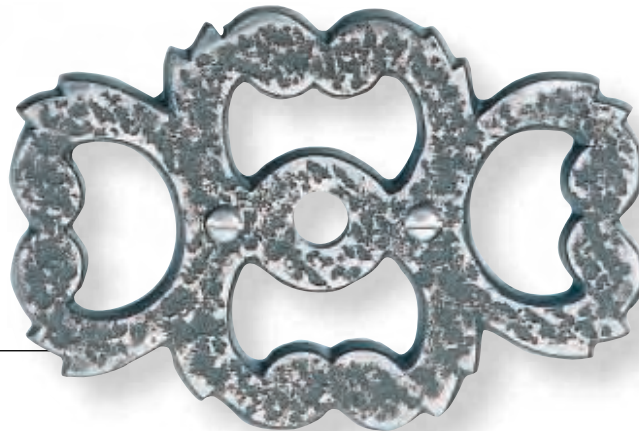

R 332
H 65 x 97mm

3

- Livrées avec kit de fixation
- Percages : 6, 8 ou 10 mm (à préciser).
- Autres percements : nous consulter.



- Fixing supplied
- Spindles : 6, 8 or 10 mm diameter centre piercing (please contact us).



- Mit einem Befestigungs kit geliefert
- Bohrungen : 6 - 8 oder 10 mm (zum Notieren).
- Andere Bohrungen : bitte fragen Sie uns.

Rosaces

Roses - Rosetten

R 334 * 1 3 5 6 7 • D.105mm

R 336 * 1 3 6 • Ø100mm

R 328 * 1 3 5 6 7 • Ø60mm

R 332 * 1 3 5 6 7 • H.65x.97mm

* 1 Noir/Black/Schwarz • 3 Poli verni/Pewter/Poliert lackiert • 5 Laiton massif/Brass/Vollmessing • 6 Rouillé ciré/Rust effect/Gerostet gebohnt • 7 Laiton vieilli/Antique brass/Geältert Messing



R.324
H 85 x 85 mm

3



R.308
Ø 80 mm

7



R.314
H 67 x 105 mm

1

- Livrées avec kit de fixation
- Perçages : 6, 8 ou 10 mm (à préciser).
- Autres percements : nous consulter.



- Fixing supplied
- Spindles: 6, 8 or 10 mm diameter centre piercing (please contact us).



- Mit einem Befestigungs kit geliefert
- Bohrungen : 6 - 8 oder 10 mm (zum Notieren).
- Andere Bohrungen : bitte fragen Sie uns.

Rosaces

Roses - Rosetten

R.324 * 1 3 5 6 7 • H 85 x 85 mm

R.308 * 1 3 5 6 7 • Ø 80 mm

R.314 * 1 3 6 • H 67 x 105 mm

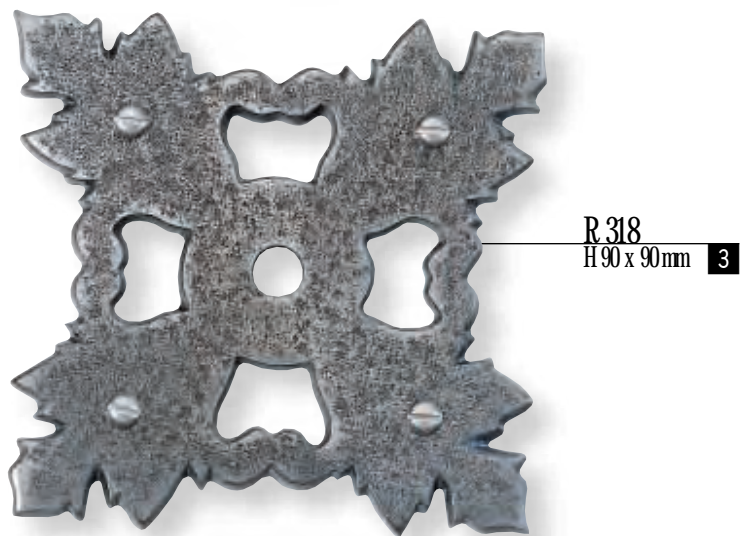
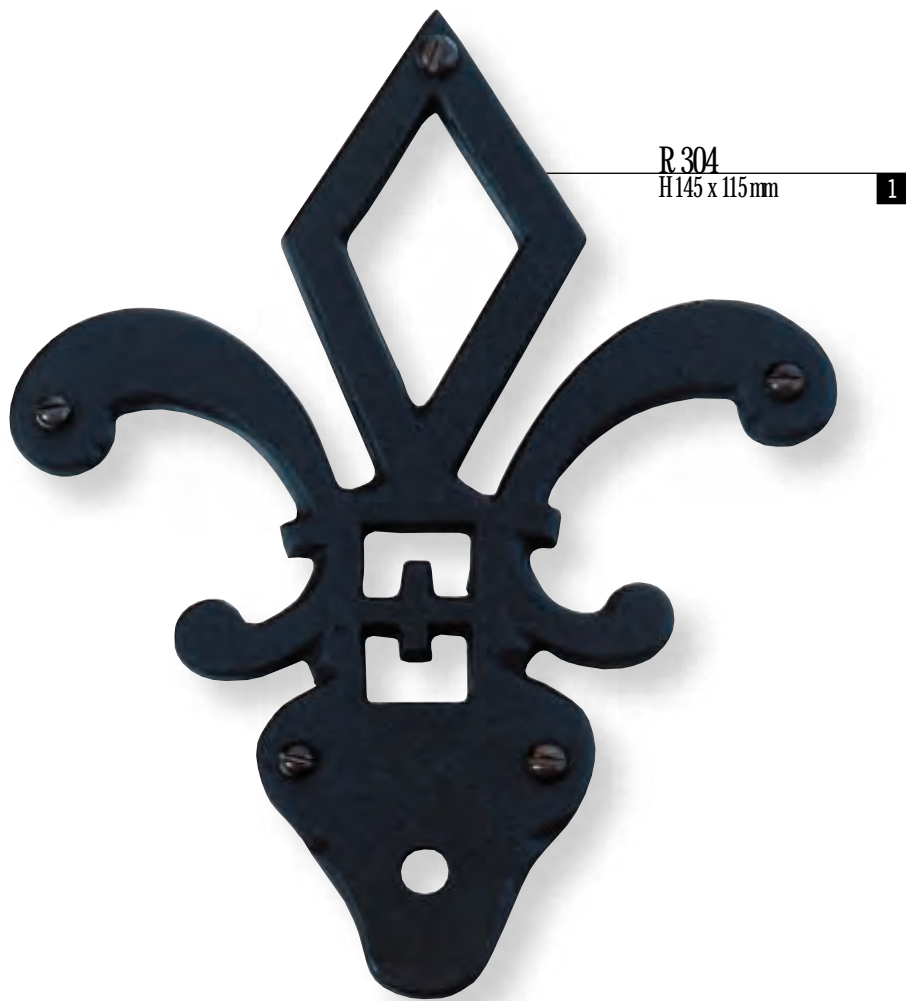

- Livrées avec kit de fixation
- Perçages : 6, 8 ou 10 mm (à préciser).
- Autres percements : nous consulter.



- Fixing supplied
- Spindles: 6, 8 or 10 mm diameter centre piercing (please contact us).



- Mit einem Befestigungs-
kit geliefert.
- Bohrungen : 6 - 8 oder 10 mm (zum Notieren).
- Andere Bohrungen : bitte fragen Sie uns.

Rosaces

Roses - Rosetten

R.304 * 1 3 5 6 7 • H145x115mm R.318 * 1 3 5 6 7 • H90 x 90 mm

7

R 326
Ø 70 mm



R 326 bis
martelée/antique/gehämmert
Ø 45 mm

3

3

R1504 lisse/smooth/Schlicht
Ø 55 mm



E 100 lisse/smooth/Schlicht
H 78 x 37 mm

5

- Livrées avec visserie.
- Perçages 6, 8 ou 10 mm (à préciser).
- Autres percements (à préciser) :
 - non percée
 - bec de cane
 - clé
 - cylindre européen
 - condamnation
- Finitions : lisse ou martelée (à préciser).
- Réf. E 100 : lisse uniquement.
- Autres finitions : (nous consulter).

- Supplied with screws.
- 6, 8 or 10 mm diameter : (please specify).
- Fixings (please specify)
 - blank
 - latch
 - keyhole
 - European cylinder
 - bathroom handle
- Product number E 100 : Only smooth

- Mit schrauben geliefert.
- Bohrungen (zum Notieren)
 - 6, 8, 10. Viereck
 - nicht gebohrt
 - Loch für Türklinke
 - Schlüssel
 - Profilzylinder
 - Abschluß
- Fertigarbeiten : schlicht oder gehämmert (zum Notieren)
- Die Referenz E 100 : nur schlicht.
- Andere Feitgarbeiten : bitte fragen Sie uns

Rosaces

Roses - Rosetten

R 326

* 1 3 5 6 7 • Ø 70 mm

R1504

* 1 3 5 6 7 • Ø 55 mm

E 100

* 1 3 5 6 7 • H 78 x 37 mm

R 326 bis

* 1 3 5 6 7 • Ø 46 mm



Accessoires décoratifs

Decoration - Zierate

Porte-clés/Key hooks/Schlüsselringe

Crochets/Hooks/Haken

Porte-embrasse/Curtain tie back/Gardineträger

Cache-interrupteur/Electrical plate/Schalterabdeckungen

Potence/Hook/Ausleger

Arrêts de volet/Shutter fasteners/Stellklappen

Arrêt de fenêtre/Casement stay/Stellfenster

Fausses charnières/Dummy hinges/Dekorative Scharniere

Fausses pentures/Hinge fronts/Dekorative Türbänder



• Livrées avec kit de fixation



• Fixing supplied



• Mit einem Befestigungs-
kit geliefert.

Fausses charnières

Dummy hinges - Dekorative-Scharniere

FC 80 * **1 3 6** • Long 270x85mm FC 78 * **1 3 6** • Long 215x60mm FC 76 * **1 3 6** • Long 180x60mm
FC 74 * **1 3 6** • Long 120x40mm

* **1** Noir/Black/Schwarz • **3** Poli verni/Pewter/Poliert lackiert • **5** Laiton massif/Brass/Vollmessing •
6 Rouillé ciré/Rust effect/Gerostet gebohnt • **7** Laiton vieilli/Antique brass/Geältert Messing



FP 77
L. 435mm

1

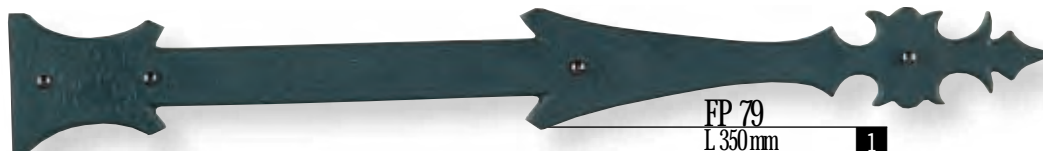

FP 79
L. 350mm

1



FP 81
L. 295mm

1



FP 83
L. 195mm

1

- Livrées avec kit de fixation



- Fixing supplied



- Mit einem Befestigungs-
kit geliefert.

Fausses pentures

Hinge fronts - Dekorative-Türbänder

FP 77 * 1 3 6 • Long 435mm

FP 79 * 1 3 6 • Long 350mm

FP 83 * 1 3 6 • Long 195mm

FP 81 * 1 3 6 • Long 295mm

* 1 Noir/Black/Schwarz • 3 Poli verni/Pewter/Poliert lackiert • 5 Laiton massif/Brass/Vollmessing •
6 Rouillé ciré/Rust effect/Gerostet gebohnt • 7 Laiton vieilli/Antique brass/Geältert Messing



FP 89
L 500mm

3

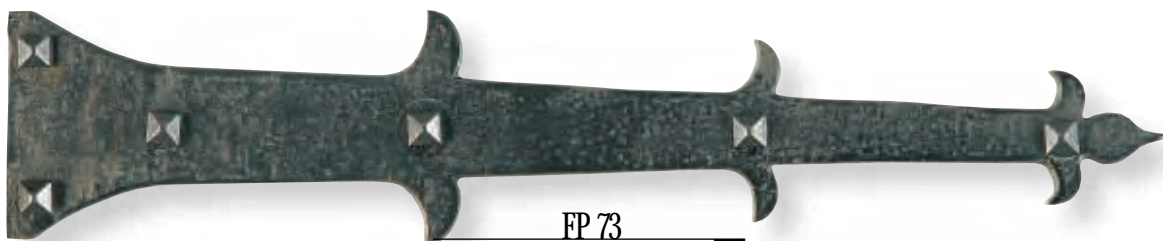

FP 73
L 450mm

3



FP 75
L 310mm

3



FP 71
L 167mm

3

• Livrées avec kit de fixation



• Fixing supplied



• Mit einem Befestigungs-
kit geliefert.

Fausses pentures

Hinge fronts - Dekorative-Türbänder

FP 89

* 1 3 6 • Long 500mm

FP 73

* 1 3 6 • Long 450mm

FP 71

* 1 3 6 • Long 167mm

FP 75

* 1 3 6 • Long 310mm

* 1 Noir/Black/Schwarz • 3 Poli verni/Pewter/Poliert lackiert • 5 Laiton massif/Brass/Vollmessing •
6 Rouillé ciré/Rust effect/Gerostet gebohntert • 7 Laiton vieilli/Antique brass/Geältert Messing



Potence
Hook/Ausleger
H 90 x 160 mm

1



Porte-enbrasse
Curtain tie back/Gardineträger
L 135 mm

7



Arrêt de volet
Shutter fasteners/Stellklappe
L 195 mm

3



Cache-interrupteur
Electrical plate/Schalterabdeckung
H 80 x 100 mm

5



Arrêt de fenêtre
Casement stay/Stellfenster
L 285 mm

3

- Livrées avec kit de fixation
- Cache-interrupteur :
(à préciser)
80 x 100 mm ou 80 x 160 mm
- Perçements : (nous consulter).

- Supplied with screws.
- Light switch or wallplug cover 80 x 100 mm or 80 x 160 mm (please specify)

- Mit einem Befestigungs kit geliefert.
- Schalterabdeckung :
(zum Notieren) 80 x 100 mm oder 80 x 160 mm
- Bohrungen : Bitte fragen Sie uns.

Décoration

Decoration - Zierate

Potence * 1 3 6 • H.90 x 160 mm

Cache-interrupteur * 1 3 5 6 7 • H.80 x 160 mm

Arrêt de fenêtre * 1 3 6 • Long 285 mm

Porte-enbrasse * 1 3 5 6 7 • Long 135 mm

Arrêt de volet * 1 3 6 • Long 195 mm

* 1 Noir/Black/Schwarz • 3 Poli verni/Pewter/Poliert lackiert • 5 Laiton massif/Brass/Vollmessing • 6 Rouillé ciré/Rust effect/Gerostet gebohntert • 7 Laiton vieilli/Antique brass/Geältert Messing



PC 400
Long 220 mm

3

DAUPHIN

Nickelé/Nickeléd/Vernickelt



DAUPHIN

Laiton/Brass/Messing

5



CRA 2

7



5

CR.GF

Laiton/Brass/Messing



CR17

Chromé/Chrome/Verchromt



CR.GF

Chromé/chrome/Verchromt



CR17

Laiton/Brass/Messing

5



- Livrées avec kit de fixation
- Finitions : à préciser.



- Fixing supplied



- Mit einem Befestigungs-
kit geliefert.
- Feitgarbeit : Bitte fragen
Sie uns.

Crochets

Hooks - Haken

PC 400 * 1 3 5 6 7 • Long 220mm

Crochet dauphin Nickelé ou laiton (à préciser)
Nickeléd/Brass, Vernickelt/Messing

CRA 2 * 1 5 7

CR.GF Chromé/Laiton, Chrome/Brass, Verchromt/Messing 5

CR17 Chromé/Laiton, Chrome/Brass, Verchromt/Messing

* 1 Noir/Black/Schwarz • 3 Poli verni/Pewter/Poliert lackiert • 5 Laiton massif/Brass/Vollmessing •
6 Rouillé ciré/Rust effect/Gerostet gebohntert • 7 Laiton vieilli/Antique brass/Geältert Messing

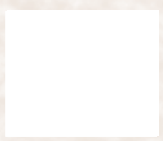

Suggestions

Suggestions - Anregungen



Suggestions

Suggestions - Anregungen

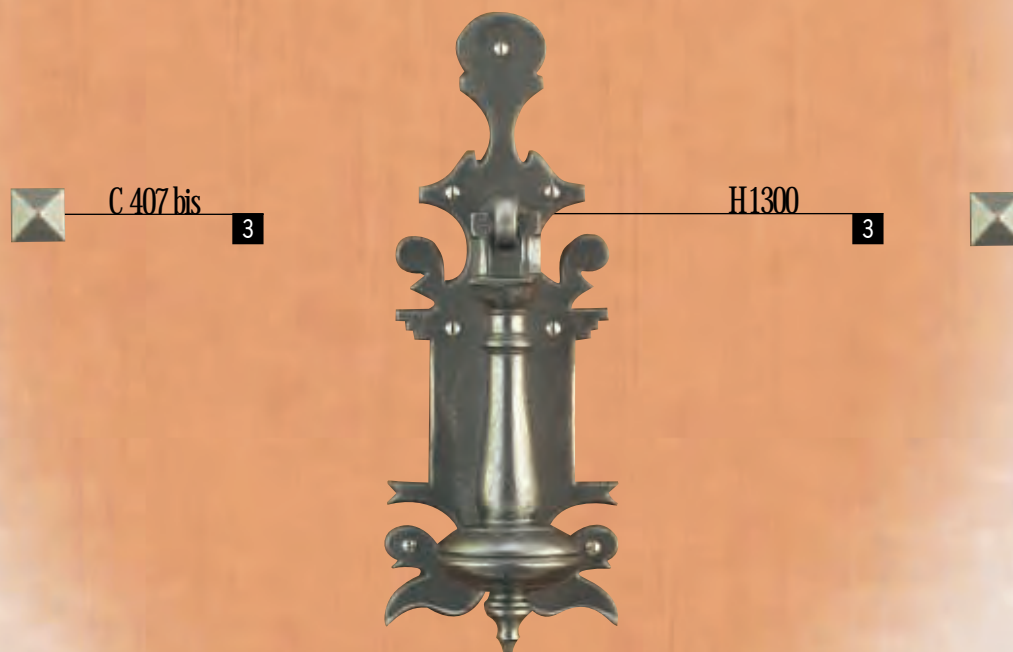
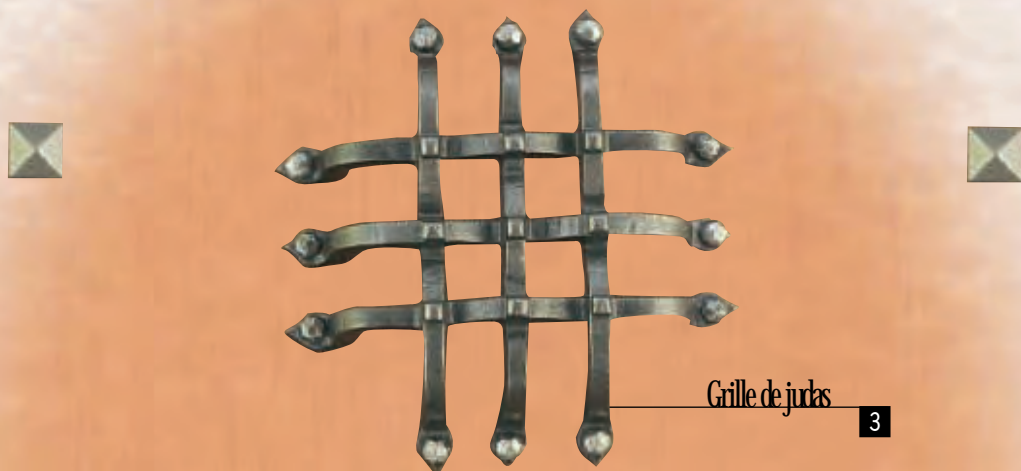

* **1** Noir/Black/Schwarz • **3** Poli verni/Pewter/Poliert lackiert • **5** Laiton massif/Brass/Vollmessing • **6** Rouillé ciré/Rust effect/Gerostet gebohntert • **7** Laiton vieilli/Antique brass/Geältert Messing



Suggestions

Suggestions - Anregungen

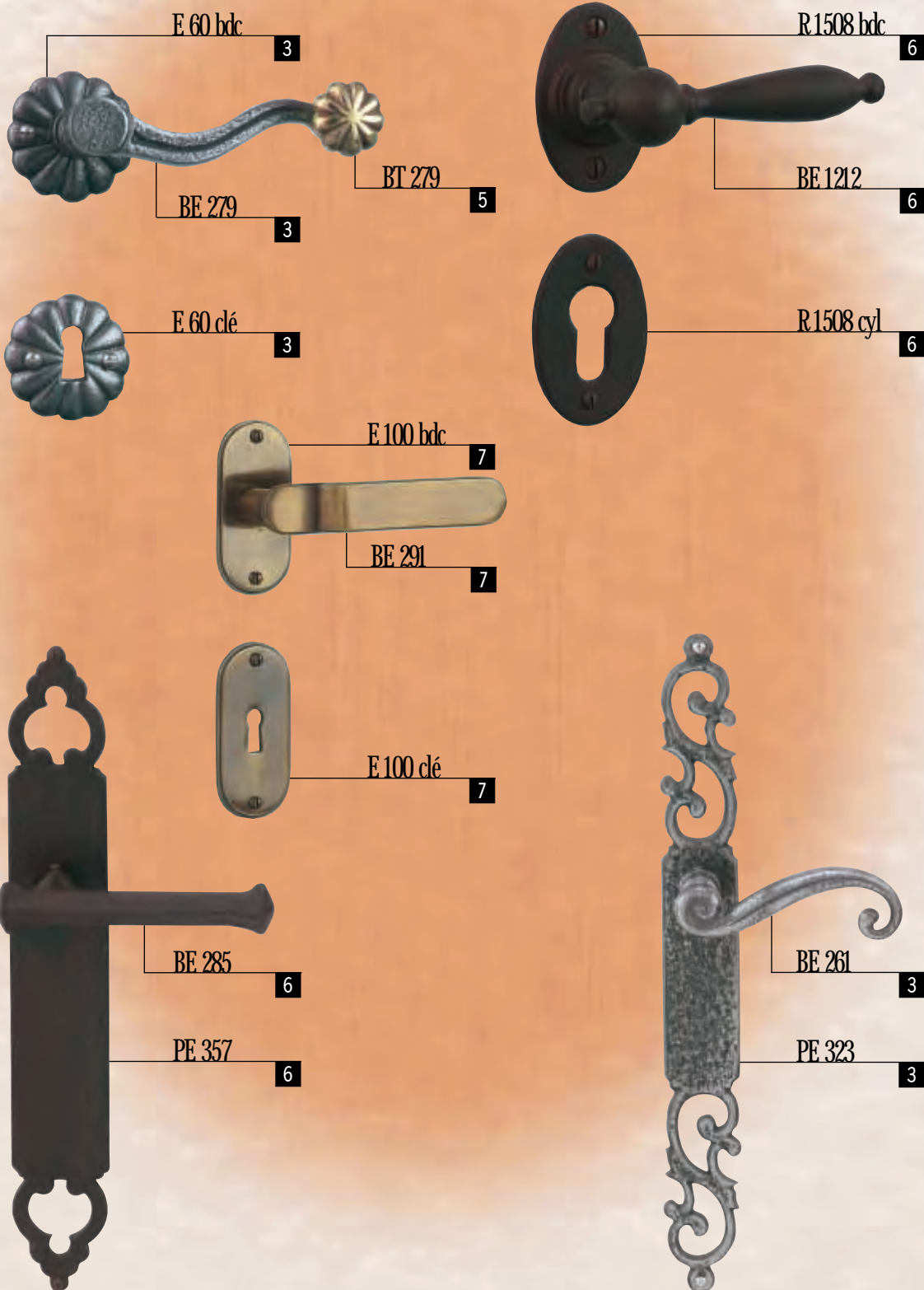

* **1** Noir/Black/Schwarz • **3** Poli verni/Pewter/Poliert lackiert • **5** Laiton massif/Brass/Vollmessing • **6** Rouillé ciré/Rust effect/Gerostet gebohnt • **7** Laiton vieilli/Antique brass/Geältert Messing



Suggestions

Suggestions - Anregungen

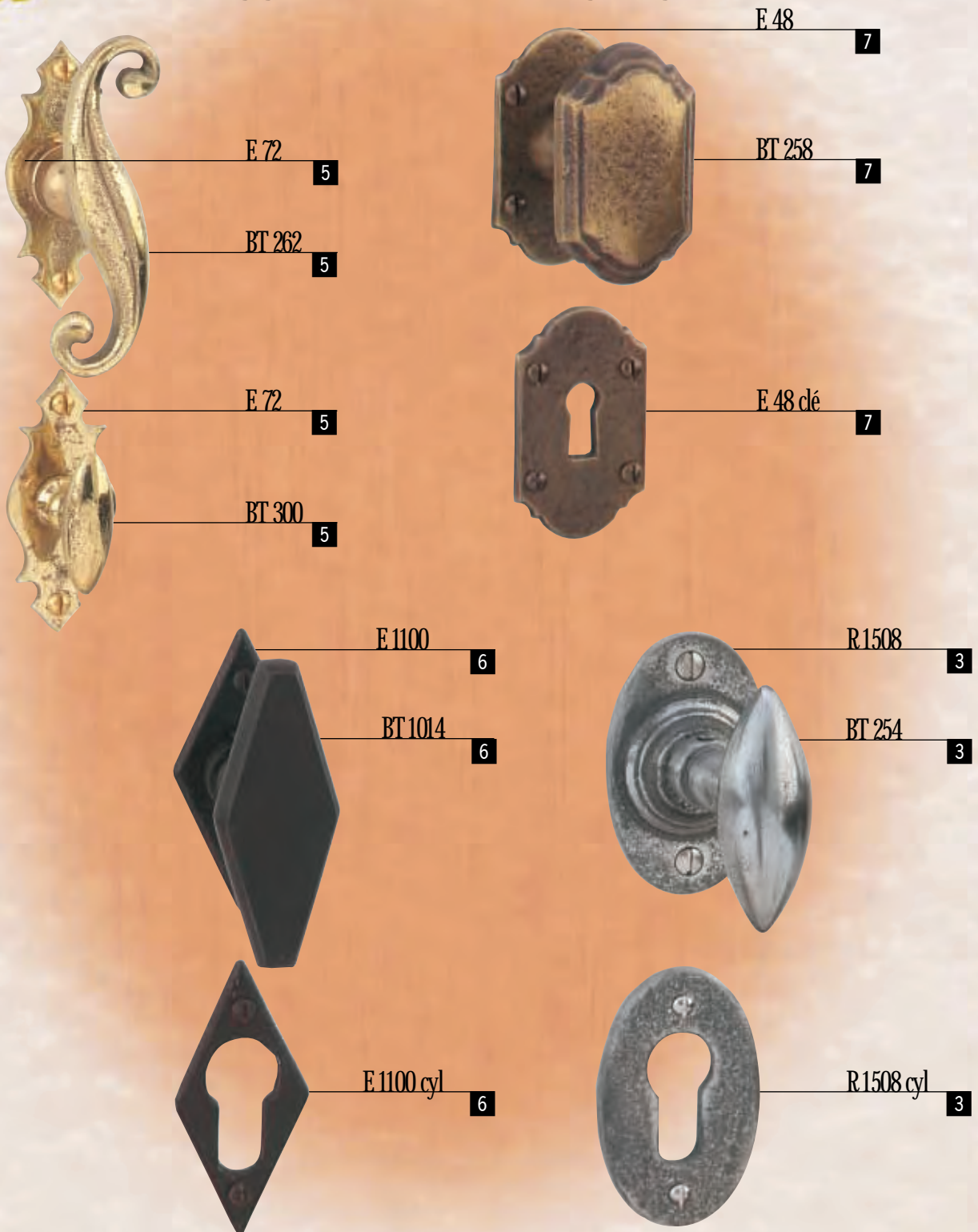

* 1 Noir/Black/Schwarz • 3 Poli verni/Pewter/Poliert lackiert • 5 Laiton massif/Brass/Vollmessing •
6 Rouillé ciré/Rust effect/Gerostet gebohntert • 7 Laiton vieilli/Antique brass/Geältert Messing



Suggestions

Suggestions - Anregungen

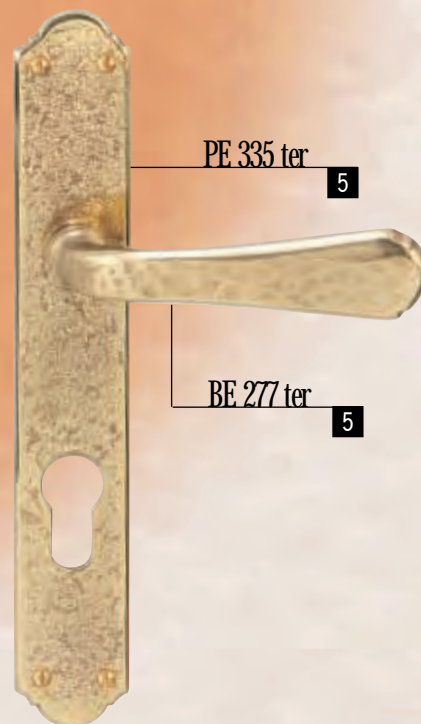
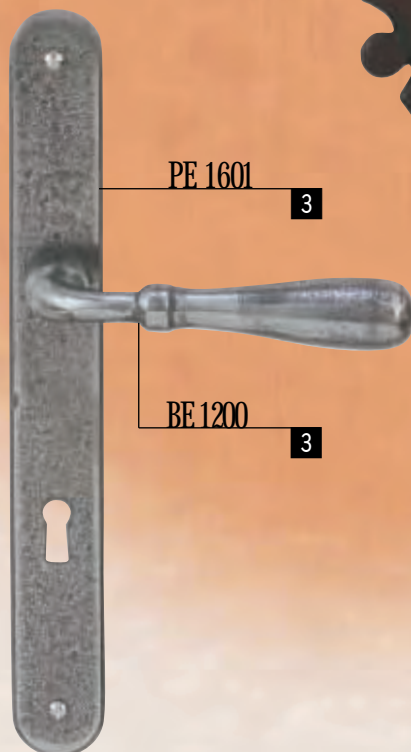
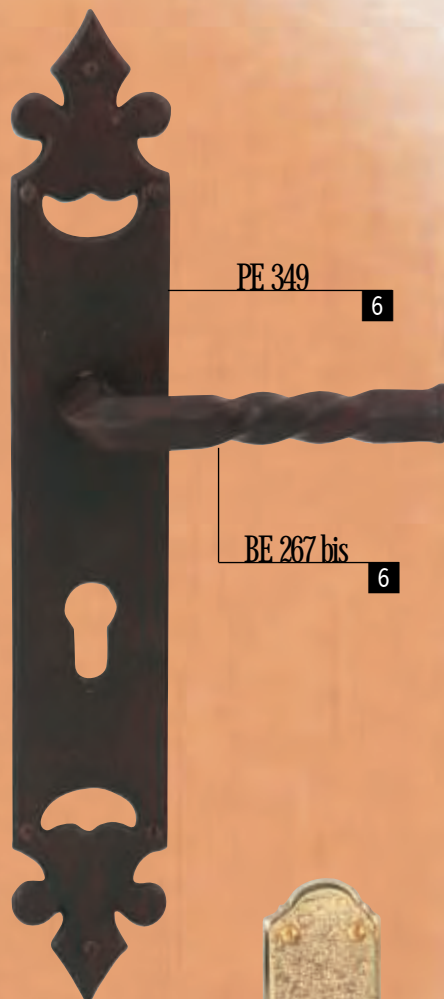
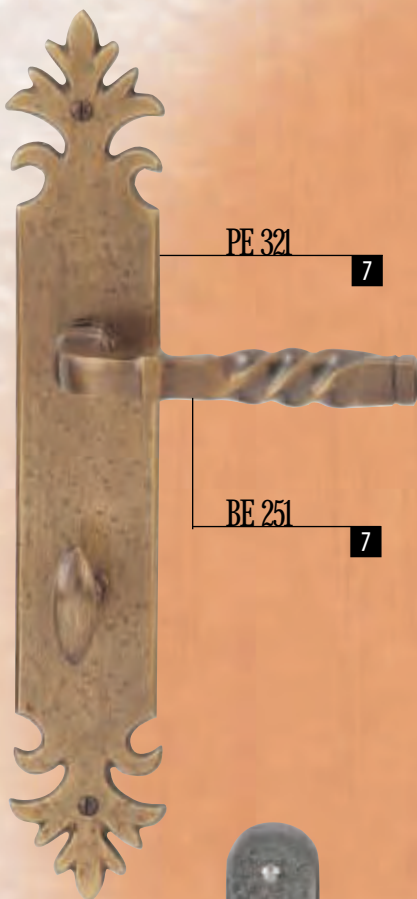

* **1** Noir/Black/Schwarz • **3** Poli verni/Pewter/Poliert lackiert • **5** Laiton massif/Brass/Vollmessing • **6** Rouillé ciré/Rust effect/Gerostet gebohntert • **7** Laiton vieilli/Antique brass/Geältert Messing



Suggestions

Suggestions - Anregungen

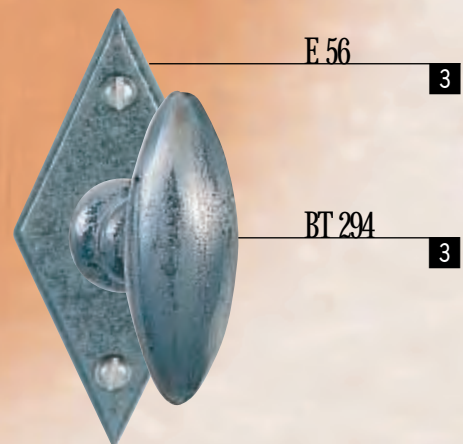
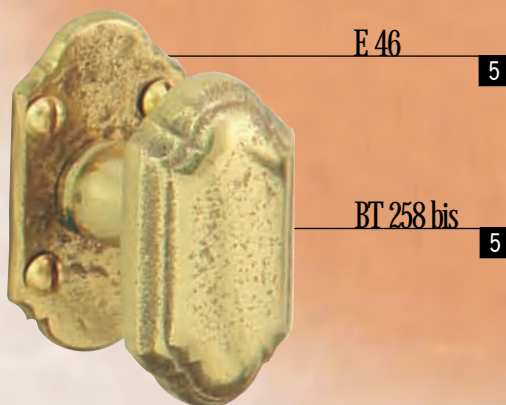
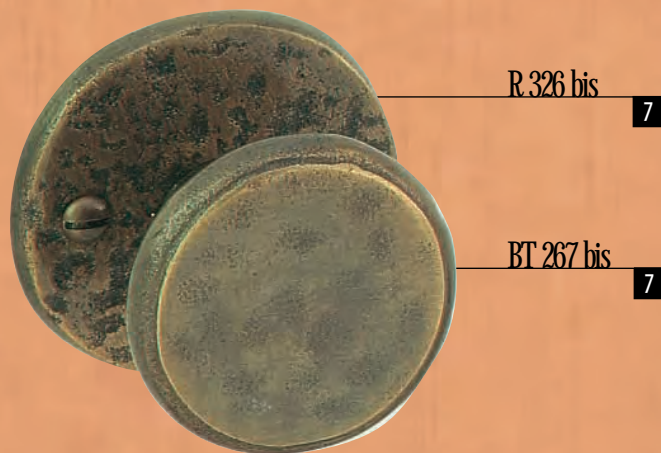

* **1** Noir/Black/Schwarz • **3** Poli verni/Pewter/Poliert lackiert • **5** Laiton massif/Brass/Vollmessing • **6** Rouillé ciré/Rust effect/Gerostet gebohntert • **7** Laiton vieilli/Antique brass/Geältert Messing



Suggestions

Suggestions - Anregungen

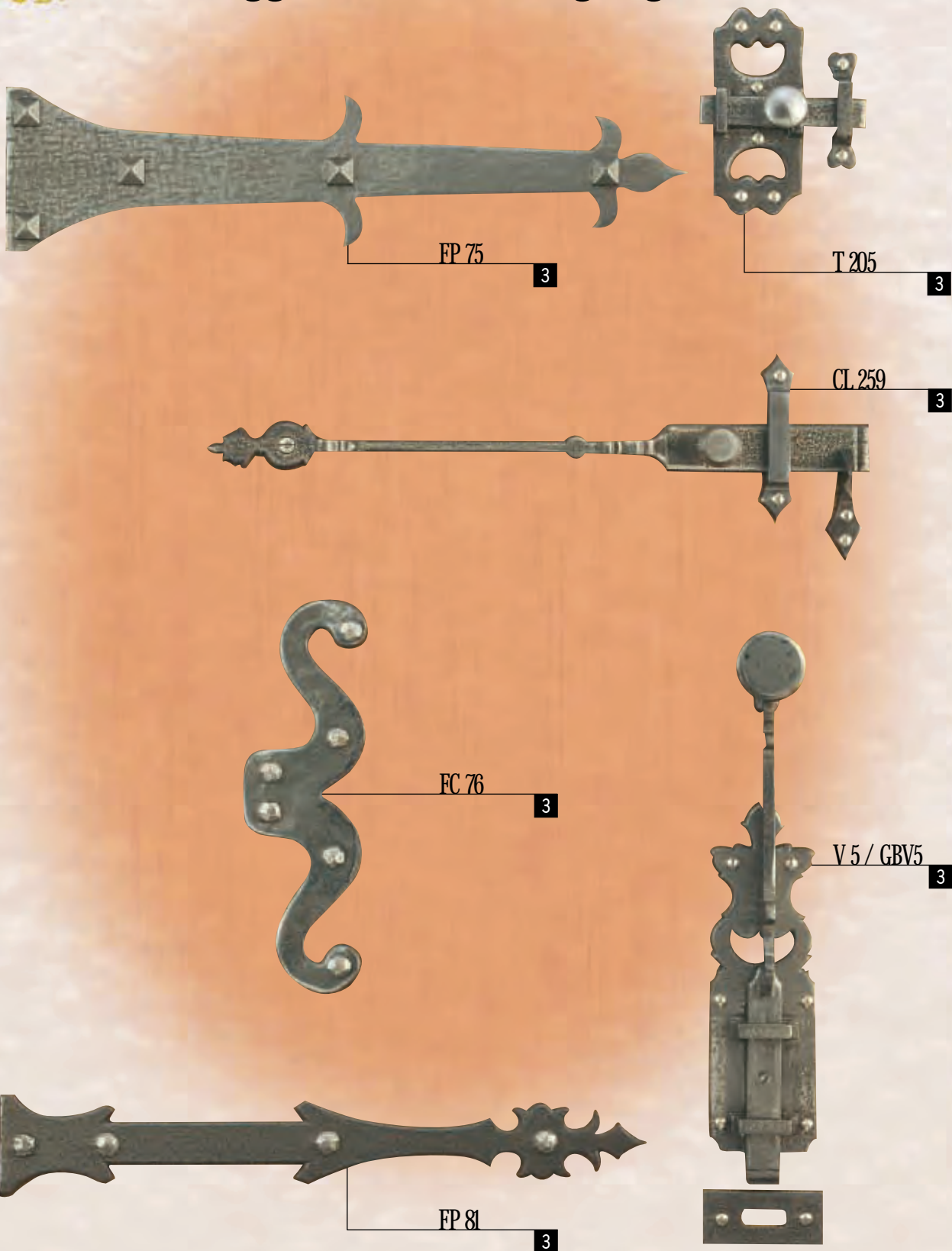

* 1 Noir/Black/Schwarz • 3 Poli verni/Pewter/Poliert lackiert • 5 Laiton massif/Brass/Vollmessing • 6 Rouillé ciré/Rust effect/Gerostet gebohntert • 7 Laiton vieilli/Antique brass/Geältert Messing



Suggestions

Suggestions - Anregungen

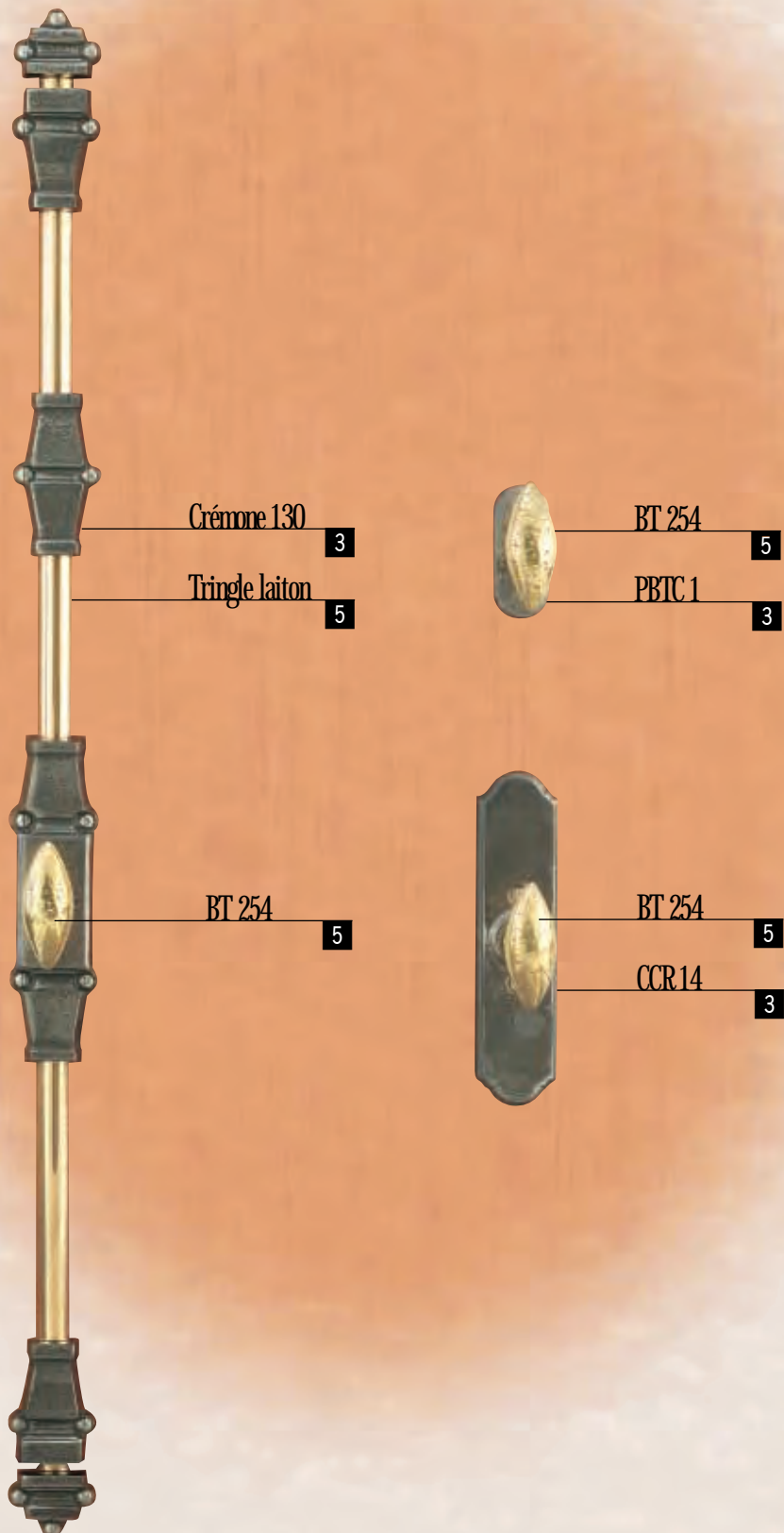

* **1** Noir/Black/Schwarz • **3** Poli verni/Pewter/Poliert lackiert • **5** Laiton massif/Brass/Vollmessing • **6** Rouillé ciré/Rust effect/Gerostet gebohntert • **7** Laiton vieilli/Antique brass/Geältert Messing



Suggestions

Suggestions - Anregungen

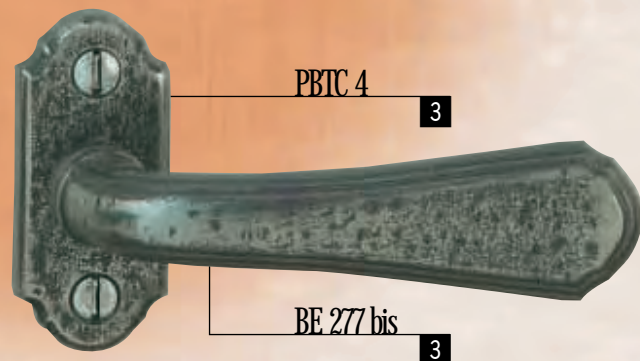
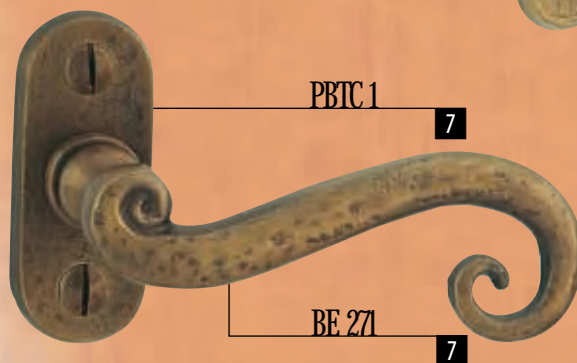
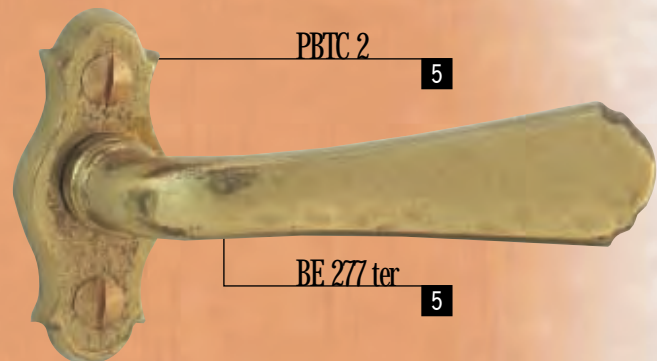
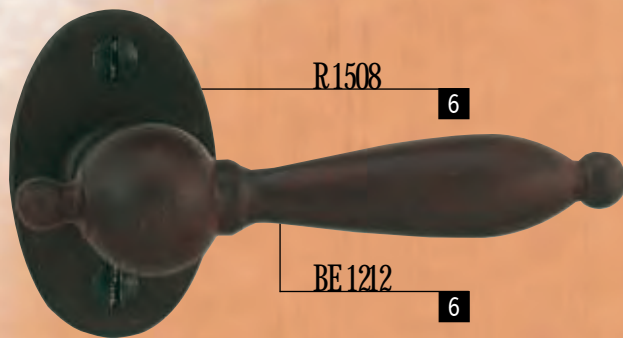

* **1** Noir/Black/Schwarz • **3** Poli verni/Pewter/Poliery lackiert • **5** Laiton massif/Brass/Vollmessing • **6** Rouillé ciré/Rust effect/Gerostet gebohntert • **7** Laiton vieilli/Antique brass/Geältert messing



Suggestions

Suggestions - Anregungen



E.56

5

BE 269

5



E.90

7

BE 279

7



E.48

5

BE 277

5

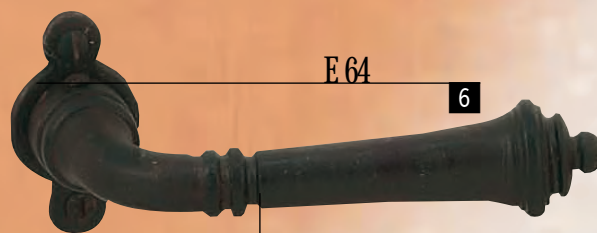

E.64

6

BE 287

6

* **1** Noir/Black/Schwarz • **3** Poli verni/Pewter/Poliert lackiert • **5** Laiton massif/Brass/Vollmessing • **6** Rouillé ciré/Rust effect/Gerostet gebohntert • **7** Laiton vieilli/Antique brass/Geältert Messing

Finitions - Finishes - Fertigarbeiten

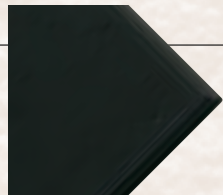

1

Noir
Black
Schwarz

FINITION "NOIR"
Produit fondu en fonte de fer recevant, après un usinage manuel, un revêtement anti-rouille "epoxy".

BLACK FINISH
Cast iron product. Machined by hand, and then coated with black antirust epoxy.

FERTIGARBEIT "SCHWARZ"
Dieses Produkt (Gußeisen) bekommt, nach einer Handbearbeitung, eine "Epoxy-Antirust" Lackierung

1

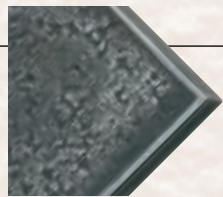

3

Poli verni
Pewter
Poliert lackiert

FINITION "FER POLI VERNI"
Produit fondu en fonte de fer recouvert, après polissage, d'un vernis incolore polyuréthane.

PEWTER FINISH
Cast iron product. Polished and then coated with a clear polyurethane varnish

FERTIGARBEIT "POLIERTES UND LACKIERTES EISEN"
Dieses Produkt (Gußeisen) bekommt, nach dem Polieren, einen farblosen Lack

3

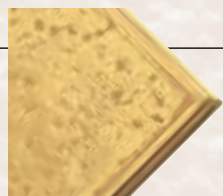
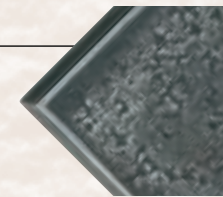

5

Laiton massif
Brass
Vollmessing

FINITION "LAITON"
Produit en laiton massif fondu dans moule sable, poli et revêtu d'un vernis nitro-synthétique.

BRASS
Pure cast brass product. Polished and then coated with a nitro-synthetic varnish

FERTIGARBEIT "MESSING"
Produkt aus Massiv-Messing geschmolzen in einer Sandform, poliert und lackiert.

5

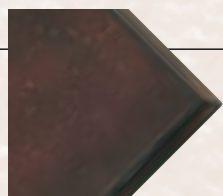
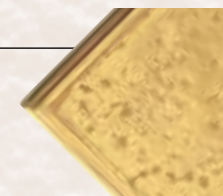

6

Rouillé ciré
Rust effect
Gerostet gebohnt

FINITION "ROUILLÉ CIRÉ"
Produit fondu en fonte de fer rouillé et encaustiqué à la main

RUST
Cast iron product. Weathered and then hand lacquered

FERTIGARBEIT "HANDGEWACHST UND MIT ROSTDESIGN"
Produkt aus Gußeisen, mit Rostdesign und handgewachst.

6

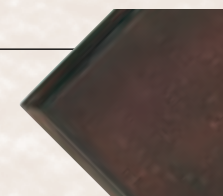

7

Laiton vieilli
Antique brass
Geältert Messing

FINITION "LAITON VIEILLI"
Produit en laiton massif fondu dans moule sable, poli, patiné à la main puis revêtu d'un vernis nitro-synthétique.

ANTIQUÉ BRASS
Pure cast brass product. Polished, hand patinated and then coated with a nitro-synthetic varnish

FERTIGARBEIT "GEALTERTES MESSING"
Produkt aus Massiv-Messing geschmolzen in einer Sandform, poliert und lackiert sowie handveredelt.

7

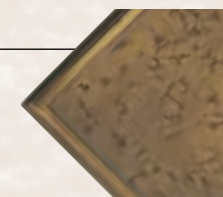

Finition "cémenté"

FINITION "CÉMENTÉ" (SUR DEMANDE)
Produit fondu en fonte de fer recevant un "cadmiage" de protection, puis dégradé et vernis de façon à retrouver l'aspect "Vieux fer".

CEMENTEX TREATMENT (ON REQUEST)
Cast iron product, rust resistant. The Cementex Treatment consists of integrating zinc particles at very high temperature to the surface of the steel. The products are then lacquered and appear as pewter.

FERTIGARBEIT "ZEMENTIERT" (AUF ANFRAGE)
Produkt aus Gußeisen Kadmium beschichtet (zum besseren Schutz), die Oberfläche wird behandelt, um ein Aussehen von Alteisen zu bekommen.

Finition "brut"

FINITION "BRUT" (SUR DEMANDE)
Produit fondu en fonte de fer poli ou non poli (à préciser à la commande), prêt à recevoir une finition autre que celles proposées.

MILL FINISH (ON REQUEST)
Cast iron product. Unpolished and unlacquered. Ready to be treated for any finish

FERTIGARBEIT "ROH" (AUF ANFRAGE)
Produkt aus Gußeisen, wahlweise poliert oder unpoliert. Dieses Produkt ist vorbereitet um jedes Finish-Design möglich zu machen